

MARSH CIVILS

WATER AND WASTEWATER TREATMENT SOLUTIONS

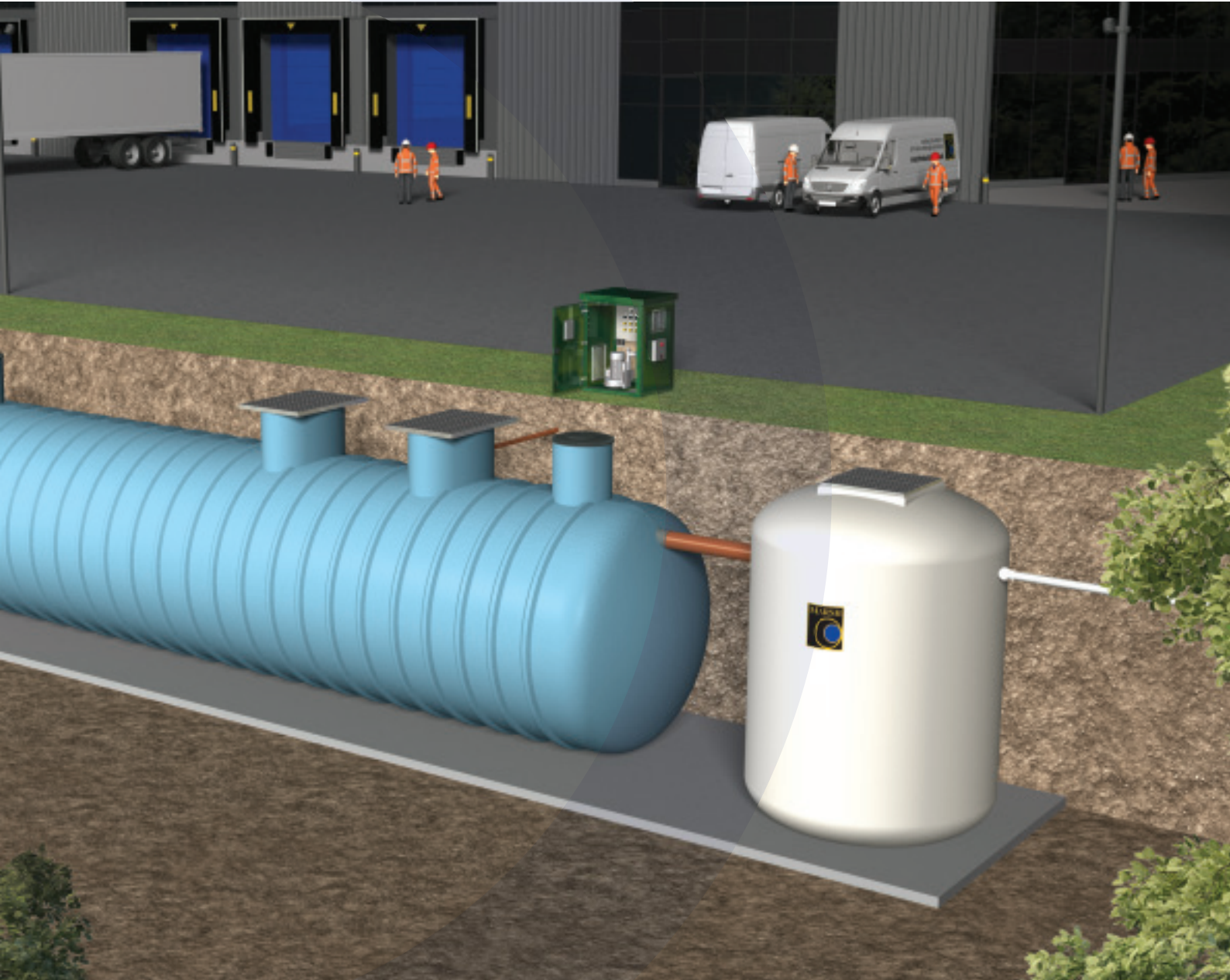

DELIVERING CONFIDENCE

As a trusted UK water and wastewater solution provider and a support team with extensive civils experience, we can help you and your team deliver project confidence.

- Fully accredited and certified water and wastewater treatment solutions
- High quality British manufacturing
- Flexible production capacity
- BIM/CAD materials support
- Wide-ranging civils project experience
- End-to-end customer service

www.marshcivils.co.uk





Marsh's experienced and knowledgeable team promptly and accurately interpret our requirements. We put full confidence in Marsh from pricing to completion for all our project requirements.

– Client testimonial

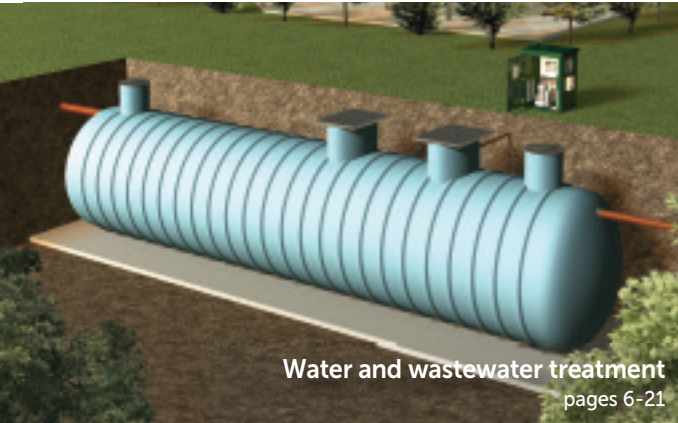

Water and wastewater treatment
pages 6-21



Pump stations and basement pumps
pages 22-29



Oil separators
pages 30-39

Water and wastewater treatment

Ultra:Polylok sewage treatment plants	6
Marsh:Standard sewage treatment plants	10
Gem-APS phosphate and ammonia reduction	12
Cesspools	14
Degrilleur trash barrier	15
Marsh GMS★ grease management systems	16
Storm Dammer stormwater flow attenuation	18
Marsh:UV ultra-violet disinfection system	20

Pump stations

WellWater:Seine	24
WellWater:Hudson	25
WellWater:Nile	26
WellWater:Amazon	27
BASE2DRAIN basement pumps	28

Oil separators

Marsh:Marator full retention oil separators	32
Marsh:Hydroil full retention separators	34
Marsh:Hydroil bypass separators	36
Marsh:Hydroil forecourt separators	37
Wash-down separators and silt traps	38

Water and wastewater treatment products



Very happy with the team's service and I feel confident in the product that has been specified.

– Client testimonial



Early engagement with the Marsh Civils team can bring product optimisation and cost savings. We recommend getting in touch as soon as possible.

Project management

With extensive experience of managing the design, manufacture and despatch of pump stations, sewage treatment plants, attenuation tanks, rainwater harvesting systems and associated products, the Marsh Civils team works closely with clients to ensure projects are delivered on time and on budget.

The company trains its team to recognised competency standards to address the growing management requirements, from order placement through to delivery and installation.

All products are backed by Marsh Industries' commercial and technical support.

Post-installation and commissioning visits are available, together with service and maintenance contracts if required.



BIM/CAD library

We host a wide range of product downloads for architects, engineers, consultants and specifiers, including BIM files (RFA files), DWG CAD files and other supporting documentation. All files are available to download at www.marshcivils.co.uk.

We also host a full technical library featuring all product information, specifications and certification.

Tank sizing and specification

For precise sizing and product specification, please contact the Marsh Civils team on 01933 829470 or email contracts@marshindustries.co.uk

Gaia Sege[©] Process design software

Developed by Marsh Industries, the unique Gaia Sege process design software uses core information to accurately calculate and tailor key variables, ensuring total optimisation for individual applications.

These precise calculations provide assurance to consultants, engineers, specifiers and contractors that the system is specifically designed to meet the appropriate standards of regulatory bodies.

Sewage treatment plants

For sewage treatment plants, the programme employs core process equations to precisely calculate and modify critical variables, ensuring total processing optimisation for Biological Oxygen Demand (BOD), Total Suspended Solids (TSS) and Ammonia (NH₄) reduction and removal.

Gaia Sege software also uses 'British Water Flows & Loads' data to calculate initial flows and loadings whilst also calculating peak flows and levels.

The programme can also calculate accurate sludge generation and storage on a daily basis, dependent upon final effluent standards required, ensuring the optimisation of primary chambers, individual clarifiers, diffused oxygen feed and final settlement chamber.

Pump chambers

Gaia Sege utilises current building regulations to calculate precise storage chamber sizes. Pump systems are determined by using friction head loss calculations based on minimum self-cleansing velocities in order to specify the best possible pump(s) for the application.

Grease traps

Appropriate grease trap sizes are generated by accounting for the amount of grease and flow generated from the grease producing facility whilst providing adequate retention time befitting of these variables.

Water attenuation tanks

Marsh Industries' rainfall storage sizing programme, Gaia Storm Dammer, can simulate the calculated flood storage required for any prolonged period within a set geographic area (ie, 1 in 5 year or 1 in 100 year rainfall).

Structural integrity testing

Structural integrity tests, performed in accordance with EN ISO 179-1/1eA: 2010-11, were undertaken to evaluate the strength of Marsh Industries' GRP materials against similar GRP materials used by other manufacturers.

Three separate material samples were submitted for impact testing; Marsh GRP material (virgin unfilled resin), a GRP material containing calcium fillers and a GRP material containing sand filler.

The tests involved 12 samples of each material at a size of 80x10x5mm. The nominal pendulum energy was 15J at an impact velocity of 3.8m/s.

Results proved Marsh GRP material to be 40% stronger than the other materials tested.

Fire resistance testing

Fire resistance testing was performed to assess ignitability of products subjected to direct impingement of flame. Marsh Industries' GRP material passed all practical testing to achieve EN ISO 11925-2:2010 standard.

Ultra:Polylok™

Sewage treatment plants

Advanced biological processing for off-mains wastewater

Overview

Marsh Ultra Polylok sewage treatment systems provide advanced biological treatment to off-mains wastewater on sites ranging from 50-500PE.

The units are ideally suited for large residential, commercial, industrial and leisure sites - particularly where onerous consent standards preclude the use of standard 'off the shelf' units.

Proven reliability of the simple but effective Submerged Aeration Filtration (SAF-MBBR) system offers both operating and financial benefits when compared to more complex alternatives that require frequent servicing and maintenance to sustain performance.

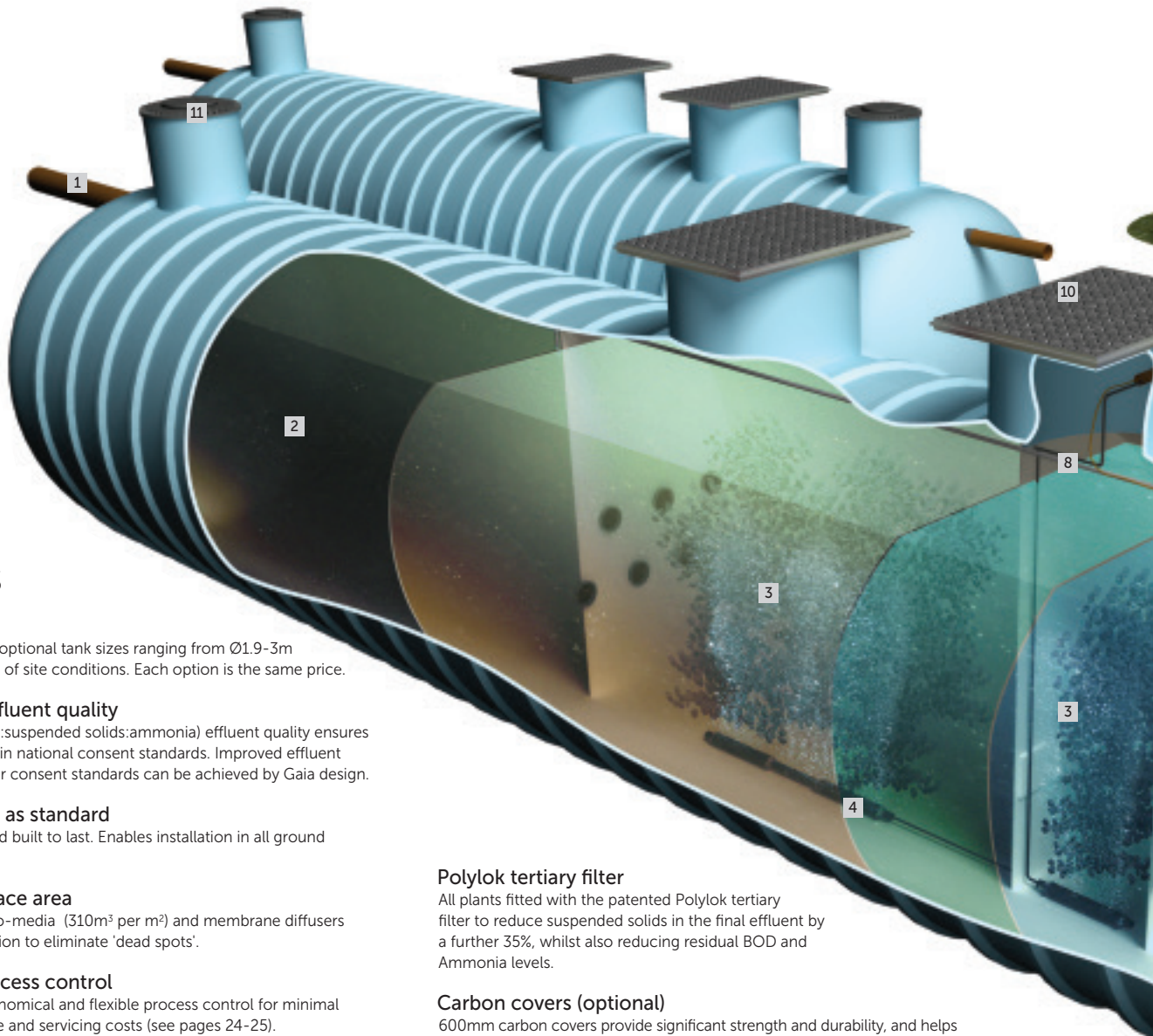

Benefits

Plant sizing

Bespoke design with optional tank sizes ranging from Ø1.9-3m satisfies the demands of site conditions. Each option is the same price.

Class-leading effluent quality

20:30:20mg/ltr (BOD:suspended solids:ammonia) effluent quality ensures discharge is well within national consent standards. Improved effluent quality to meet tighter consent standards can be achieved by Gaia design.

Heavy duty shell as standard

Structurally sound and built to last. Enables installation in all ground conditions.

High media surface area

High specification bio-media (310m² per m³) and membrane diffusers provide even circulation to eliminate 'dead spots'.

Eco-friendly process control

Energy-efficient, economical and flexible process control for minimal running, maintenance and servicing costs (see pages 24-25).

For sites that do not need the ability to regulate process control, Marsh can offer diaphragm compressors for sewage treatment plants up to 150PE

Internal recirculation

Continues the treatment process to provide higher effluent quality whilst balancing flow over 24 hour period or periods of intermittent use.

Polylok tertiary filter

All plants fitted with the patented Polylok tertiary filter to reduce suspended solids in the final effluent by a further 35%, whilst also reducing residual BOD and Ammonia levels.

Carbon covers (optional)

600mm carbon covers provide significant strength and durability, and helps to reduce possible odours. Heavy duty access covers also provided.

Optional extras

Optional extras include extensions for deep installations, pumped outlets for sites with adverse levels, sample chambers, Degrileur trash barriers, phosphate reduction and UV treatment chambers.

Key

- 1 Inlet
- 2 Primary chamber
- 3 Aeration chambers
- 4 Air diffusers
- 5 Final (or 'humus') chamber
- 6 Polylok filter
- 7 Outlet
- 8 Recirculation to primary chamber
- 9 Turret guard
- 10 Heavy duty access covers
- 11 Carbon covers (optional)
- 12 High level alarm
- 13 Eco-friendly process control
- 14 Control kiosk



This is not a typical tank installation. Configuration and components are shown for illustration purposes only

Tank sizing

Developed by Marsh Industries, the unique Gaia Sege process design software uses core information to accurately calculate and tailor key variables, ensuring total system optimisation for individual applications.

These precise calculations provide assurance to consultants, engineers, specifiers and contractors that the system is specifically designed to meet the appropriate standards of regulatory bodies.

For Ultra:Polylok sewage treatment plants, the programme employs core process equations to precisely calculate and modify critical variables, ensuring total processing optimisation for Biological Oxygen Demand (BOD), Total Suspended Solids (TSS) and Ammonia (NH_4) reduction and removal.

Gaia Sege software also uses 'British Water Flows & Loads' data to calculate initial flows and loadings whilst also calculating peak flows and levels.

The programme can also calculate accurate sludge generation and storage on a daily basis, dependent upon final effluent standards required, ensuring the optimisation of primary chambers, individual clarifiers, diffused oxygen feed and final settlement chamber.

GRP kiosks

Marsh GRP kiosks provide safe and secure storage of electrical control panels and other tank monitoring equipment.

The kiosks are typically fitted with one or two doors, depending on kiosk size, with stainless steel vents and yale locks.



Energy-efficient, economical and flexible process control for Ultra:Polylok™ sewage treatment plants

Efficiency

Air blower speed/output is controlled using a variable speed 'drive' which supplies the precise amount of air required to enable the sewage treatment plant to function efficiently.

Optimisation of the air blower output results in improved running costs, meaning the end user can be assured they have the most economical solution for their wastewater system. This is a unique feature when it comes to overall energy-efficiency as most process control kiosks currently available within the industry have a one size fits all approach.

Flexibility

These next generation process control kiosks are built with flexibility in mind. Additional control options can be programmed into the 'drive' to regulate the volume of air delivered to the sewage treatment plant for different periods. This can be particularly beneficial for seasonal applications such as campsites, caravan parks, lodges or hotels where they may operate at peak capacity for short periods of the year. This functionality permits the volume of air to be increased or reduced, depending on the amount of people to be accommodated, thereby offering the end-user the ability to further reduce energy and running costs.

In addition, the process control kiosk allows for system expansion in the case of business/site growth (subject to design), thus eliminating the need to install extra tanks, pipework, air blowers, etc.

Noise reduction

We believe these kiosks to be the quietest on the market. They are fitted with a number of noise reduction measures as standard, making them ideal for caravan parks, campsites, etc, subject to kiosk placement/location. This may reduce the need for creating barriers or planting to restrict noise.

Further noise reduction measures can be added through the use of acoustic PUNF foam linings and various acoustic noise absorbing baffles. This not only reduces noise, but also enables the kiosk to be placed in a more convenient location, on sites where space is at a premium (the recommended distance from the sewage treatment plant should be 10m).

Specification/costs of noise reduction options, including measured decibel levels at a given distance from the kiosk, can be supplied on request.



Features

- **Powder coated, mild steel or GRP kiosk (Green - RAL6005)**
The kiosk protects the motor and controls from the elements
- **Forced ventilation, including ambient temperature control**
A ventilation fan/thermostat maintains the optimal ambient temperature in accordance with the air blower manufacturer's specifications
- **Thermal protection on motors**
Protects the motor windings from overheating, increasing the reliability and lifespan of the motor
- **Electrical overload and short circuit protection**
As required by electrical regulations
- **Air intake filter maintenance alarm**
Alerts the end-user when the intake filter needs cleaning/replacing
- **High pressure alarm**
Alerts the end user if the system design pressure has been exceeded, typically suggesting a blockage or restriction in the pipework
- **Low pressure alarm**
Alerts the end user if the system design pressure is low, typically suggesting a leakage in the pipework
- **Standard acoustic attenuation including air intake silencer and external acoustic hood**
Reduces noise from the blower motor and air intake

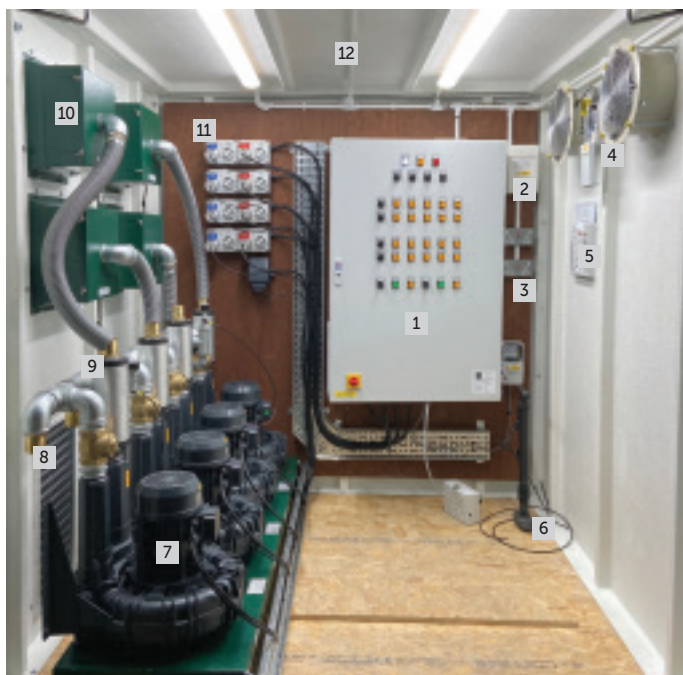

Key

- 1 Electrical control panel
- 2 Kiosk lighting and power DB
- 3 230v RCD sockets
- 4 Kiosk ventilation fans/thermostat control box
- 5 Electrical panel drawings and documents
- 6 Test equipment (for use when commissioning)
- 7 Aeration blowers
- 8 Pipe manifold including 50mm outlets and return valves
- 9 Air intake silencer
- 10 Aeration blower intake filter
- 11 Blower power and control outlets
- 12 Kiosk lighting

Specifications

Ultra:Polylok		Kiosk					
Model	People served	Height	Width	Depth	Power rating Kw	Recommended electrical supply 230v	Recommended electrical supply 400v
UP55	55	1350	850	500	0.8	230v SP&N 16A type C/D MCB	400v TP&N 10A type C/D MCB
UP75	75	1350	850	500	0.8	230v SP&N 16A type C/D MCB	400v TP&N 10A type C/D MCB
UP100	100	1350	850	500	1.1	230v SP&N 20A type C/D MCB	400v TP&N 16A type C/D MCB
UP125	125	1350	850	500	1.1	230v SP&N 20A type C/D MCB	400v TP&N 16A type C/D MCB
UP150	150	1350	850	500	1.1	230v SP&N 20A type C/D MCB	400v TP&N 16A type C/D MCB
UP175	175	1350	850	500	1.1	230v SP&N 16A type C/D MCB	400v TP&N 16A type C/D MCB
UP200	200	1350	850	500	1.5	230v SP&N 25A type C/D MCB	400v TP&N 20A type C/D MCB
UP225	225	1350	850	500	1.5	230v SP&N 25A type C/D MCB	400v TP&N 20A type C/D MCB
UP250	250	1350	850	500	2.2	230v SP&N 40A type C/D MCB	400v TP&N 32A type C/D MCB
UP275	275	1350	850	500	2.2	230v SP&N 40A type C/D MCB	400v TP&N 32A type C/D MCB
UP300	300	1350	850	500	3.0	230v SP&N 50A type C/D MCB	400v TP&N 40A type C/D MCB
UP325	325	1450	950	500	3.0	230v SP&N 50A type C/D MCB	400v TP&N 40A type C/D MCB
UP350	350	1450	950	500	3.0	230v SP&N 50A type C/D MCB	400v TP&N 40A type C/D MCB
UP375	375	1450	950	500	3.0	230v SP&N 50A type C/D MCB	400v TP&N 40A type C/D MCB

Notes:

- > The dimensions given on this page are for guidance only
- > For precise kiosk and Ultra:Polylok sewage treatment plant sizes and configurations, please contact Marsh Civils
- > All dimensions in mm

Maintenance

Our engineers will advise on the appropriate maintenance plan once the site installation has been completed, however the process controls installed within the kiosk are designed to alert you to any imminent maintenance required on the system.

Installation

All kiosks are supplied fully assembled, tested and ready for installation. An electrical supply/connection to the kiosk should be all that is required on site (electrical supply requirements will be supplied upon kiosk specification).

Marsh:Standard

Cost-effective sewage treatment

Biological processing for off-mains wastewater

Overview

Marsh:Standard cost-effective sewage treatment systems provide biological treatment to off-mains wastewater on large residential, commercial, industrial and leisure sites ranging from 50-300+PE.

Proven reliability of the simple but effective Submerged Aeration Filtration (SAF-MBBR) system offers both operating and financial benefits when compared to more complex and expensive alternatives that require frequent servicing and maintenance to sustain performance.

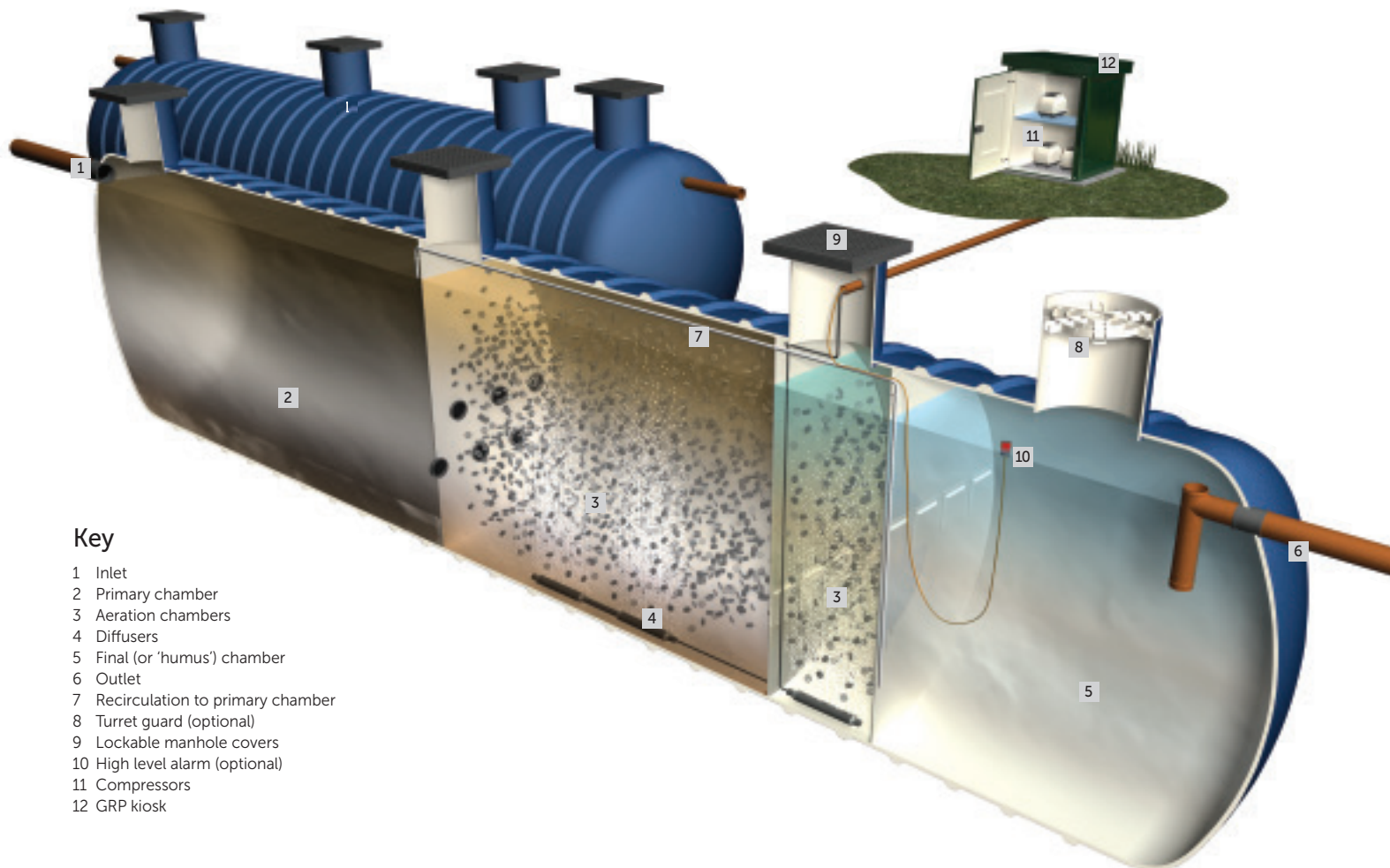

Key

- 1 Inlet
- 2 Primary chamber
- 3 Aeration chambers
- 4 Diffusers
- 5 Final (or 'humus') chamber
- 6 Outlet
- 7 Recirculation to primary chamber
- 8 Turret guard (optional)
- 9 Lockable manhole covers
- 10 High level alarm (optional)
- 11 Compressors
- 12 GRP kiosk

This is not a typical tank installation. Configuration and components are shown for illustration purposes only

Benefits

Plant sizing

Designed to BS12255, systems are available from 50-300+ PE in sizes ranging from Ø2.5-3m satisfying the demands of virtually all site conditions.

Class-leading effluent quality

Designed to British Water loadings (150litres per person, 60mg BOD litre and 8mg/litre Ammonia) ensures effluent discharge is well within national consent standards.

Cost-effective operation and maintenance

Systems have no internal moving parts and require minimal ongoing maintenance.

Heavy duty shell as standard

Structurally sound and built to last. Enables easy installation in all ground conditions.

High media surface area

High specification bio-media (310m³ per m²) and membrane diffusers provide even circulation to eliminate 'dead spots'.

Low energy compressor(s)

Easily accessible low energy compressor for minimal running, maintenance and servicing costs. Integral alarm detects low pressure in air line.

Internal recirculation

Continues the treatment process to provide higher effluent quality whilst balancing flow over 24 hour period or periods of intermittent use.

Lockable manhole covers

600mm lockable manhole covers provide significant strength and durability, and helps to reduce possible odours.

Health and Safety considerations

The Marsh:Standard can be fitted with many safety features including turret guards, failure alarms for compressor components and high level alarms.

Optional extras

Optional extras include carbon covers for odour control, turret guards for additional safety, polylok filters to further reduce suspended solids, high level alarms and telemetry for monitoring, and risers/pumped outlets for deeper installations.

Manufactured in the UK

All units are manufactured in our twin manufacturing plants at Kettering and Bridgwater. The tanks are constructed using GRP (virgin unfilled resin – no 'fillers' such as chalk) providing consistent wall thickness ensuring superior structural strength and durability.

Specifications

Model	Population served	Width +/-50mm	Length +/-50mm	Height +/-50mm	Inlet		Outlet		Turrets x 4 Ø	Desludge Days
					Invert	Ø	Invert	Ø		
MS55	50-55	2500	4160	2950	600	160	800	160	600	90
MS60	60	2500	4470	2950	600	160	800	160	600	90
MS70	70	2500	5350	2950	600	160	800	160	600	90
MS85	85	2500	6000	2950	600	160	800	160	600	90
MS100	100	2500	6950	2950	600	160	800	160	600	90
MS125	125	2500	8550	2950	600	160	800	160	600	90
MS150	150	2500	10200	2950	600	160	800	160	600	90
MS200	200	2500	13400	2950	600	160	800	160	600	90
MS250	250	3000	9650	3450	600	160	800	160	600	60
MS300	300	3000	9650	3450	600	160	800	160	600	45

- > Pumped outlets are available
- > The dimensions given on this page are for guidance only
- > For precise tank sizes and configurations, please contact Marsh Civils
- > All dimensions in mm

GEM-APS EN12566-7 Certified Aerated Precipitation System

Eco-friendly, economical phosphate and ammonia reduction

Introducing the latest innovation in our extensive portfolio of wastewater treatment solutions: the Marsh Gem-APS (Aerated Precipitation System)

Remote alert monitoring available for dosing. This can alert either Marsh Industries or the occupier when additional chemicals are required (including SMS/Telemetry options).

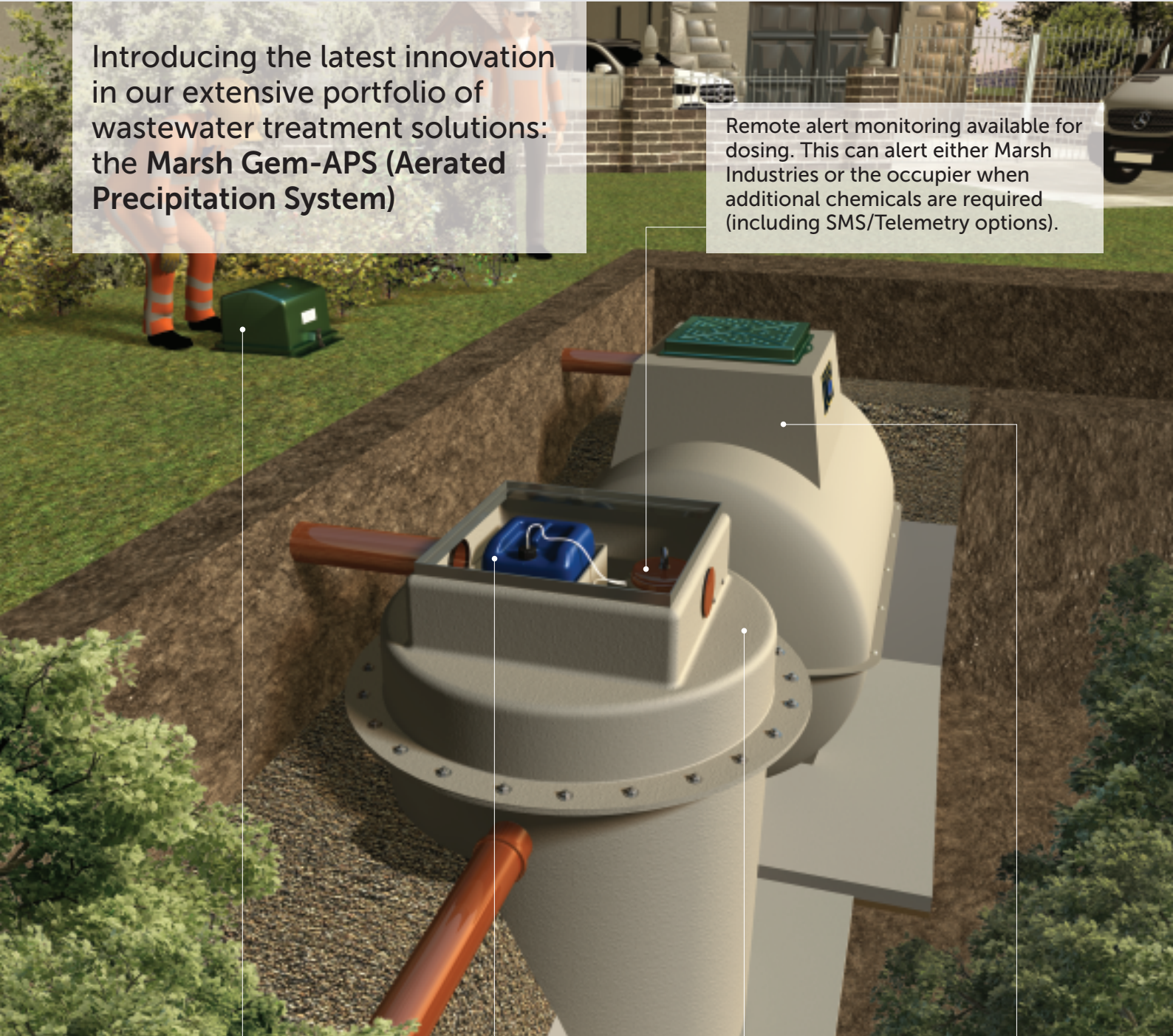

Air blower and control panel housing
Chemical dosing process is pre-configured based upon the expected flows and loads of the sewage treatment plant

Chemical dosing components
Controlled process involving chemical dosing and aeration

Gem-APS
Economical, efficient, and cost-effective phosphate, ammonia and BOD reduction unit

Package sewage treatment plant
The Gem-APS can be positioned at the outlet end of any existing sewage treatment plant (dependent on sizing)



The Gem-APS is a unique innovation for use on sites where phosphate discharge is a problem or where ammonia and BOD requirements are strict for planning consent.

Overview

The Gem-APS is designed to further reduce phosphates, ammonia and BOD from wastewater that has been previously treated in a domestic sewage treatment plant.

Positioned at the outlet end of any existing sewage treatment plant, the Gem-APS treats the discharged wastewater in a controlled process, involving small volumes of chemical dosing and aeration, in compliance with British Water and local environmental regulations, allowing the remaining effluent to be safely discharged to a river, ditch or drainage field.

Chemical dosing amounts are pre-configured based upon the expected flows and loads of the sewage treatment plant (Full scaleable detail available). The Gem-APS can also be regulated to reduce phosphate levels further.

For precise sizing and product specification, please contact the Marsh Civils team on 01933 829470 or email contracts@marshindustries.co.uk

Marsh offers commissioning and servicing of the Gem-APS, it is strongly advised to use this service when setting up the unit.

Benefits

- Tested in accordance with BS EN 12566-7 Annex A at PIA GmbH test facility in Aachen, Germany
- Small footprint and shallow dig for easy installation provides enhanced health and safety benefits
- Heavy duty shell as standard enables installation in all ground conditions. Unique 'keying-in' lip assists anchoring into granular or concrete surrounds
- Near silent, energy efficient compressor (located externally) with integral alarm
- Unique Polylok tertiary filter reduces suspended solids helping to extend drainage field life
- Lockable lid for safety and security
- Low level chemical alarm/indicator to ensure continuous phosphorus reduction. Remote alert monitoring also available.

Guidance notes

- The Marsh Gem-APS phosphate and ammonia reduction unit should discharge effluent into a drainage field.
- The Gem APS can dose Iron or aluminium
- Environment Agency guidance states the following in relation to aluminium discharge limits to surface water:

"Aluminium is acutely toxic to fish. For discharges to receiving waters with a lower 95-percentile pH value greater than or equal to 6, the EQS is a maximum allowable concentration (MAC) of 1mg/l (total).

However, we will also apply an emission standard of 10mg/l (dissolved) as a maximum concentration in the effluent if dilution is greater than 1:10. These standards reduce the possibility of active aluminium occurring downstream of the discharge. They also minimise deposition of particulate aluminium on the bed of a watercourse. At dilutions of less than 10:1 the total aluminium standard also limits dissolved aluminium in the discharge.

Aluminium limits for receiving waters with low pH

Aluminium in receiving waters with a low pH may remain in solution or re-dissolve. These waters are likely to already contain some dissolved aluminium, so the capacity to accept more will be limited.

We therefore apply different limits for aluminium in discharges to receiving waters that have a lower 95-percentile pH value of less than 6.

For soft waters, where the calcium carbonate concentration is less than 20mg/l annual average, the EQS is a 95-percentile limit of 75µg/l (dissolved).

MAC of 100µg/l (dissolved) we will apply an emission standard of 500µg/l (total) as a maximum concentration in the effluent. For hard waters, where the calcium carbonate concentration is greater than or equal to 20mg/l annual average, the EQS is a: 95-percentile limit of 500µg/l (dissolved).

MAC of 1mg/l (dissolved) we will apply an emission standard of 1mg/l (total) as a maximum concentration in the effluent. For receiving waters that already contain aluminium, we consider discharge limits on a detailed, site-specific basis".

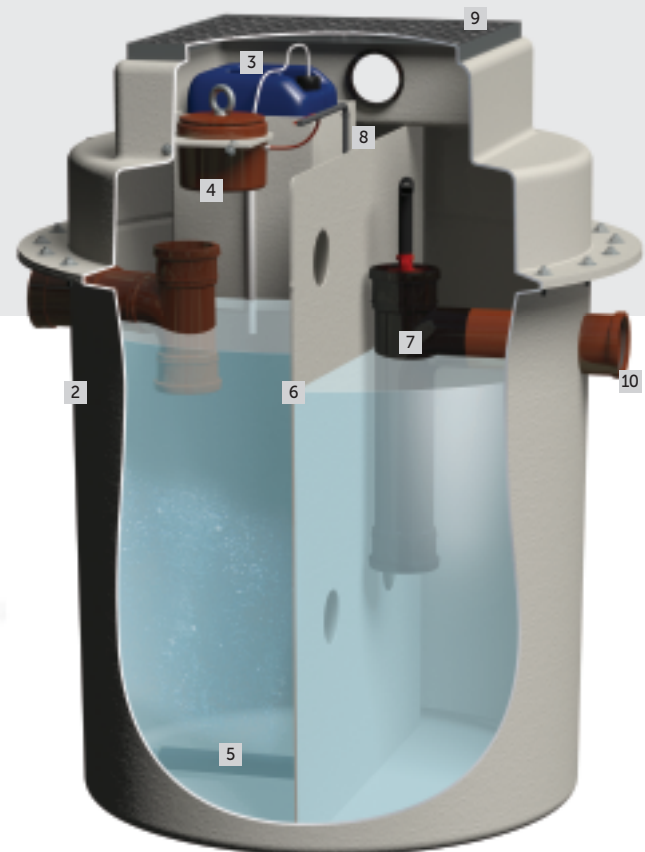

Features

- 1 Inlet
- 2 GRP tank appropriately sized for the sewage treatment plant
- 3 Dosing chemical container
- 4 Dosing chemical pump in watertight housing
- 5 Aeration diffuser(s)
- 6 Separating baffle with grate to stop media migration
- 7 Polylok filter for solids and flocculent capture
- 8 Pipework and sludge return
- 9 Lockable lid for safety and security
- 10 Outlet

Phosphate: 0.9mg/L
Ammonia: 0.4mg/L
BOD: 2mg/L



Cesspools

For firewater, Elsan waste, silage and aviation fuel storage

Overview

Designed and manufactured in accordance with BS4994/ BSEN976, the Marsh range of cesspools provides environmentally safe storage of firewater, Elsan waste, silage and aviation fuel.

Available in capacities up to 100,000 litres in Ø2.5m and Ø3m diameters, the tanks are manufactured using GRP (virgin unfilled resin - no 'fillers' such as chalk) providing consistent wall thickness ensuring superior structural strength and durability. This also enables the tank to be significantly lighter for on-site handling/positioning and better suited to withstand greater hydrostatic pressures when in use.

The tanks are supplied with a chemically resistant gel-coat that protects the fibres in the laminates and provides excellent water and chemical resistance. This inherent integrity allows Marsh to offer an unrivalled 50 year design life, backed by a 25 year structural guarantee.

Guidance notes

- Reference should be made to DEFRA guidance notes 'The Control of Pollution (Silage, Slurry and Agricultural Fuel Oil) Regulations - UK' and gov.uk guidance 'Storing silage, slurry and agricultural fuel oil'

Optional Bauer fittings are available

Specifications

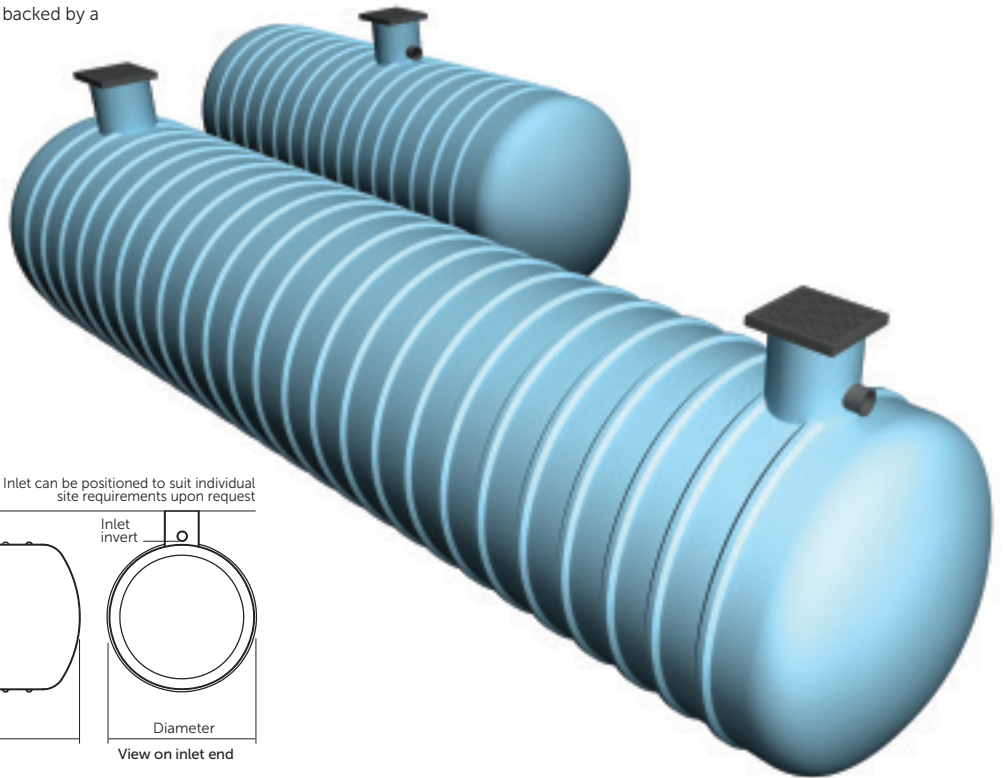
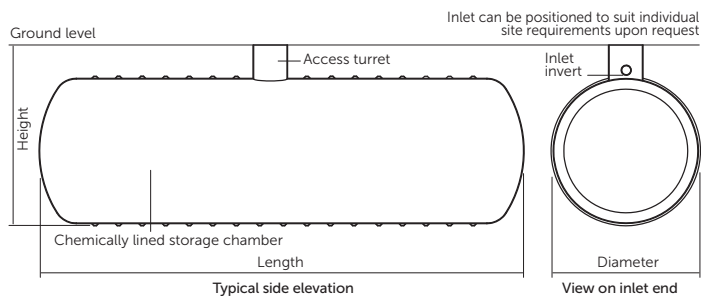

Ø2.5m tanks

Capacity Litres	Dia Ø	Length	Height	Inlet Invert	Turret size	No. of Turrets
20,000	2500	4500	3100	500	Ø600x600	1
25,000	2500	5550	3100	500	Ø600x600	1
30,000	2500	6500	3100	500	Ø600x600	1
35,000	2500	7550	3100	500	Ø600x600	1
40,000	2500	8600	3100	500	Ø600x600	2
45,000	2500	9600	3100	500	Ø600x600	2
50,000	2500	10600	3100	500	Ø600x600	2
55,000	2500	11600	3100	500	Ø600x600	2
60,000	2500	12600	3100	500	Ø600x600	2
65,000	2500	13600	3100	500	Ø600x600	2
70,000	2500	14700	3100	500	Ø600x600	2

Ø3m tanks

Capacity Litres	Dia Ø	Length	Height	Inlet Invert	Turret size	No. of Turrets
40,000	3000	6200	3600	500	Ø600x600	1
45,000	3000	6900	3600	500	Ø600x600	1
50,000	3000	7600	3600	500	Ø600x600	1
55,000	3000	8300	3600	500	Ø600x600	1
60,000	3000	9000	3600	500	Ø600x600	2
65,000	3000	9800	3600	500	Ø600x600	2
70,000	3000	10500	3600	500	Ø600x600	2
75,000	3000	11200	3600	500	Ø600x600	2
80,000	3000	11900	3600	500	Ø600x600	2
85,000	3000	12600	3600	500	Ø600x600	2
90,000	3000	13300	3600	500	Ø600x600	2
95,000	3000	14000	3600	500	Ø600x600	2
100,000	3000	14700	3600	500	Ø600x600	2

Notes:

- > The dimensions given on this page are for guidance only
- > For precise tank sizes and turret configurations, please contact Marsh Civils
- > All dimensions in mm

Benefits

- Available in capacities from 20,000 to 100,000 litres in Ø2.5 and Ø3m diameters
- Designed to meet latest UK and European standards
- Heavy duty shells enable installation in all ground conditions
- Variable invert depths and orientations to suit individual site conditions
- Optional high-level alarm available
- Guaranteed for 25 years with a design life of 50 years

Degrilleur™

Trash barrier for sewage treatment plants and pump chambers

Overview

When non dissolvable objects are flushed into the sewer and then into a sewage treatment plant or pump station downstream, it can lead to blockages or worse - possible plant failure.

To combat this Marsh Industries has developed the 'Degrilleur' - a bar screen which prevents any unsuitable materials from entering the system.

The unit has no moving parts and requires no electrics and is suitable for domestic, commercial and industrial installations.

The Degrilleur can also be used as a flow splitting chamber in multi-stream sewage treatment plants or as an upstream trash screen as part of stormwater attenuation systems.

Operating principle

The Marsh Degrilleur, positioned ahead of the system inlet, blocks the debris and forces it to rise to the top of the chamber where it is collected in a retaining trough for disposal.

Key

- 1 Inlet (110 or 160mm)
- 2 Grill and frame
- 3 Perforated retaining trough
- 4 Outlet (110 or 160mm)
- 5 Manhole cover

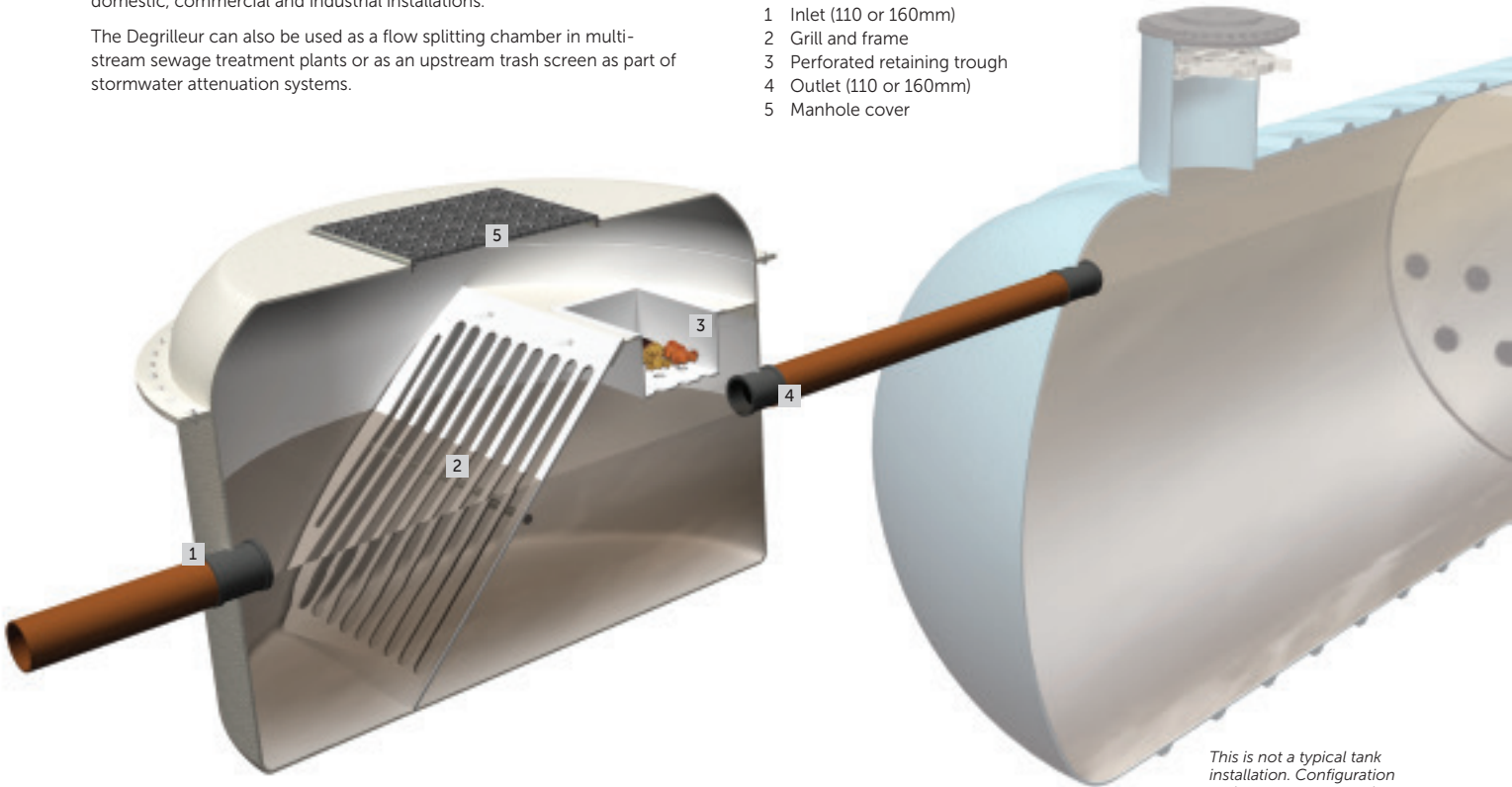

This is not a typical tank installation. Configuration and components are shown for illustration purposes only

Specifications

Cylindrical Degrilleur

Model	Diameter over flanges +/-50mm	Height +/-50mm
MID-1	1950	1283

Horizontal Degrilleur

Model	Diameter over flanges +/-50mm	Height +/-50mm	Length over flanges +/-50mm
MID-2	1950	2284	2860
MID-3	1950	2284	5200

- Notes:
- > The dimensions given on this page are for guidance only
 - > For precise tank sizes and turret configurations, please contact Marsh Civils
 - > All dimensions in mm



Marsh GMS★ Grease traps

Innovative and reliable grease management systems

Overview

Available in capacities from 2800 to 20,000 litres, Marsh Industries' Grease Management System (GMS★) range of grease traps effectively prevents Fats, Oils and Grease (FOG) from entering the drainage network or sewage treatment plants.

Testing and verification

Marsh Industries has reassessed the currently prescribed testing methods for grease traps and devised its own unique test rig and analysis at Loughborough University.

The rig, put to test for 12 months, addressed calls from the industry for clarity in testing procedures of grease trap technology. After completing trials, the new range of grease traps are the only products of their type that have been successfully tested using materials that match the FOG used in the food industry, as opposed to the traditional test method of using heating oils.

A white paper, published by Marsh, titled "A New way forward for Meaningful Testing of Grease Traps", reports on analysis from the tests carried out at Loughborough University and can be downloaded from www.marshcivils.co.uk

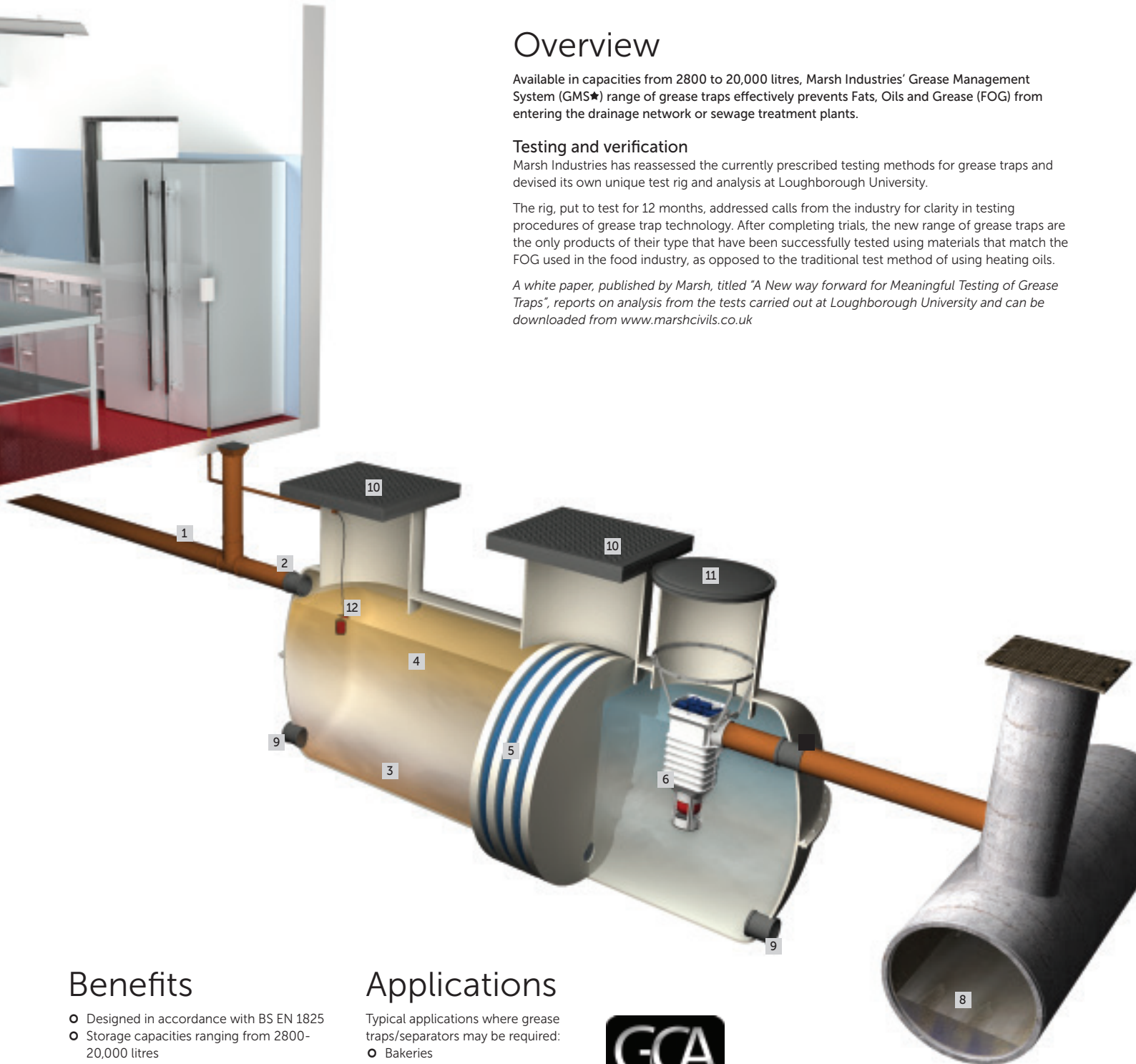

Benefits

- Designed in accordance with BS EN 1825
- Storage capacities ranging from 2800-20,000 litres
- Advanced coalescent filter system
- Bespoke design tailored to individual project specifications
- Adjustable turret and invert height
- Optional Polylok filter for further wastewater treatment
- Optional high level alarm

Applications

Typical applications where grease traps/separators may be required:

- Bakeries
- Canteens/kitchens
- Fast food restaurants
- Food processing factories
- Hotels
- Public houses
- Restaurants
- Social clubs



Marsh Industries is proud to support the Grease Contractors Association (GCA). The GCA is a non-profit organisation of specifiers, installers and maintainers of grease management systems
www.britishwater.co.uk/page/GCA

This is not a typical tank installation. Configuration and components are shown for illustration purposes only

Operating principle

The Marsh GMS★ grease trap provides sufficient storage in its primary chamber allowing for adequate solidification of FOG molecule structures before passing through an advanced coalescing filtration system.

The coalescing filtration system contains different grades of filter to prevent solids and waste passing into the final settlement chamber.

In larger units, an optional Ultra Polylok UV Filter is available which can provide further treatment to residual solids and can also destroy viruses, parasites and other pathogenic bacteria.

Key

- 1 Wastewater pipe
- 2 Tank inlet
- 3 Solids retention
- 4 Fats, oils and grease (FOG) retention
- 5 Advanced coalescing filter
- 6 Polylok filter (optional)
- 7 Tank outlet
- 8 Mains sewer system
- 9 Additional desludge points (optional)
- 10 Heavy duty manhole cover
- 11 Outlet access
- 12 High level alarm (optional)

Marsh GMS★ Roundel Compact grease management system

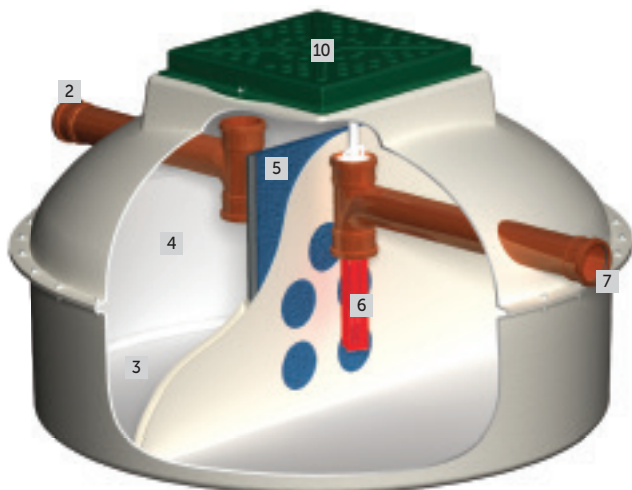

Specifications

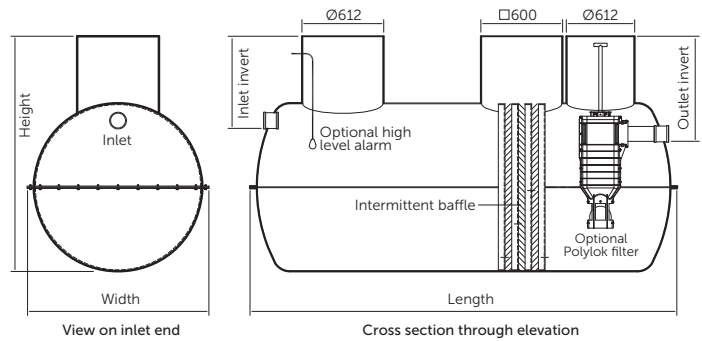

Model	Size Litres	Width +/-50mm	Length +/-50mm	Height +/-50mm	Inlet		Outlet	
					Invert	Ø	Invert	Ø
MG2800	2800	1352	3040	1732	685	110	800	110
MG3800	3800	1352	4040	1732	685	110	800	110
MG4500	4500	1572	2960	2092	685	110	800	110
MG6000	6000	1952	3090	2332	685	110	800	110
MG8000	8000	1952	3780	2332	685	160	800	160
MG10000	10000	1952	4340	2332	685	160	800	160
MG12000	12000	1952	5640	2332	685	160	800	160
MG14000	14000	1952	5980	2332	685	160	800	160
MG16000	16000	1952	6840	2332	685	160	800	160
MG18000	18000	1952	7640	2332	685	160	800	160
MG20000	20000	1952	8240	2332	685	160	800	160

Marsh Industries' GMS 'Roundel' – Ø1812 x 1m high – is shallow, compact and provides easy installation, particularly in urban areas or sites with arduous ground conditions and reduces the risk of undermining existing structures, pipelines or cable ducts.

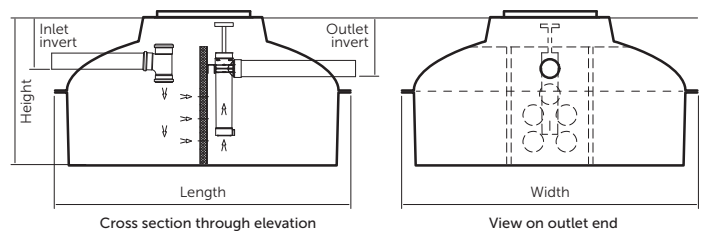

Model	Size Litres	Width +/-50mm	Length +/-50mm	Height +/-50mm	Inlet		Outlet	
					Invert	Ø	Invert	Ø
Roundel	2000	Ø1980	Ø1980	1000	350	110	400	110

Notes:

- > The dimensions given on this page are for guidance only
- > For precise tank sizes and configurations, please contact Marsh Civils
- > All dimensions in mm

Storm Dammer®

Stormwater flow attenuation

Overview

Available in capacities from 2800-110000 litres in multiple configurations with tank sizes ranging from Ø1.2m to Ø3m diameters, the Storm Dammer alleviates the risk of flooding and reduces pressure on drains/sewers by storing the excess flow of stormwater before controlled discharge downstream.

Greater capacity, ease of inspection and maintenance makes Storm Dammer the industry choice for developers, municipal planners and civil engineers.

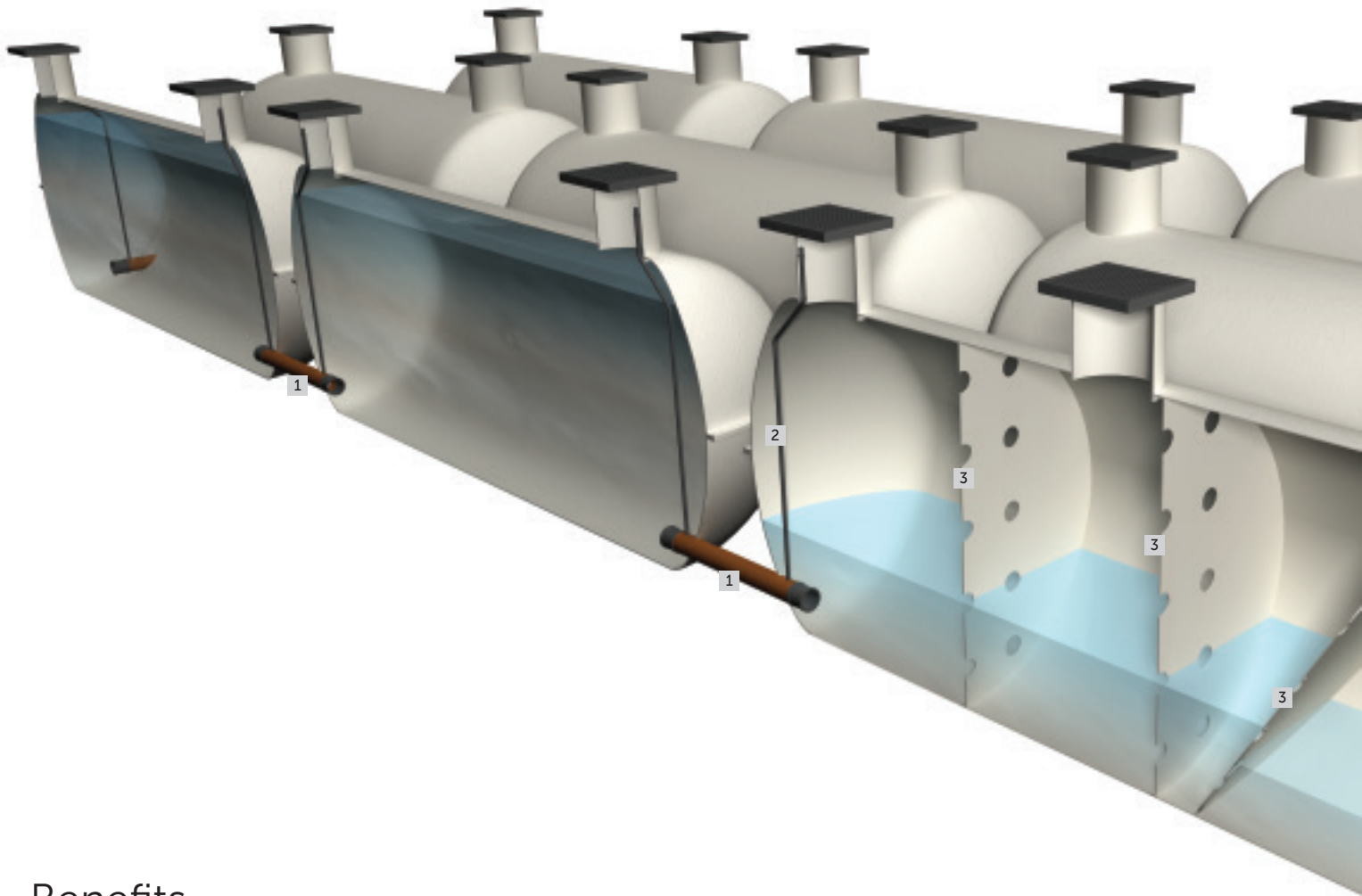

Benefits

- Designed to meet latest UK and European standards
- Multiple tank configurations and inlet orientations to suit storage and site layout requirements
- Tank diameters range from Ø1.2 to Ø3m with length up to 20 metres
- Heavy duty shells manufactured from virgin unfilled resin provides superior structural strength and durability. This also enables the tank to be significantly lighter for on-site handling/positioning and better suited to withstand greater hydrostatic pressures when in use
- Tank design offers easy access for inspection, maintenance and cleaning when compared to inaccessible crate systems
- Systems can be fitted with flow control devices and orifice plates to regulate storage and discharge
- Easily accessible, low energy submersible pumps ensure minimal running, maintenance and servicing costs
- Guaranteed for 25 years with a design life of 50 years

Key

- 1 Connecting pipework
- 2 Internal vent pipes
- 3 Flow control devices
- 4 Outlet
- 5 Access manways

Fittings and accessories

Orifice baffles

Utilising Marsh Industries' unique Gaia Storm Dammer program, in conjunction with the Micro Drainage Design program, the standard range of Storm Dammer tanks are designed using orifice baffles as the primary flow attenuation system.

Precise calculations from the Gaia Storm Dammer program ensures that the correct type of orifice baffles are distributed throughout the system to deliver the optimum outflow required.



Flood and storm control valves

Storm Dammer systems can be designed to include Vortex Storm Control units which can reduce out-flow on varying scales.

Pumps can also be fitted to upline chambers allowing stored water to be distributed to other chambers that may not be in the immediate area.



Pumps

Marsh Industries works in partnership with major UK pump manufacturers to develop attenuation tanks and pump chambers that are designed to distribute water to the mains drainage network or to other off-site storage tanks. Pumps can be supplied as single, twin or multi-line installations in both single and three phase.



AUTOadapt™ sump pump

Designed for a range of water and wastewater applications, the AUTOadapt pump removes the complexity of standard submersible pumps by combining all external sensors switches and cables from the pit within the pump itself. This simplifies installation and operation, vastly increasing reliability.

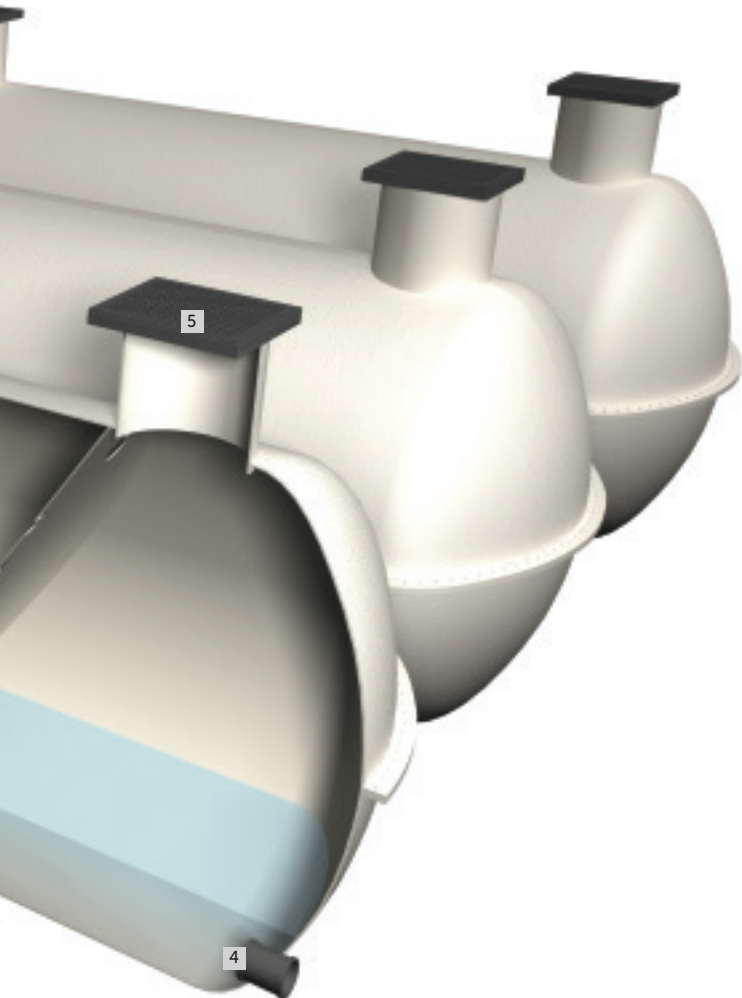

Marsh:UV

Effluent disinfection for off-mains drainage

Overview

Marsh Industries has developed an innovative UV disinfection system which removes 99% faecal coliform bacteria levels from sewage treatment plant effluent.

The Marsh:UV Disinfection Unit can be supplied as an integral part within the Marsh Ultra:Polylok range of sewage treatment plants (50-500+PE) or as a stand-alone unit which can be installed at the outlet end of any existing sewage treatment plant.

The UV light(s) are mounted in a sub-assembly which can be easily removed for periodic servicing and bulb replacement. In stand-alone units, the light assembly is mounted in a primary chamber by an anodized aluminium frame. The frame seals against the inner surface of the primary chamber to prevent flow bypass.

When the disinfection unit is filled with waste water, the ultraviolet light source operates continuously with a lamp surface temperature range of 105-120°F providing optimum UV light output and long lamp lifetime (Power supply is via 230v Single Phase with consumption of a single UV lamp being 45 watts).

In addition to the UV disinfection assembly, microfibre tertiary filters are attached at the inlet pipe to reduce any remaining suspended solids, residual BOD and ammonia levels.

UV treatment performance

A single UV maximum flow through the unit is rated at 16m³ per day or a peak flow rate .056 litres per second under the following conditions:

- UV dosage is greater than 5mJ/cm²
- Suspended Solids – less than 30 mg/litre
- BOD (5 days) – less than 30 mg/litre
- If the effluent is cleaner than the above figures the level of treatment is greater

From the above conditions, the faecal coliform reduction by the Marsh:UV Disinfection Unit exceeds 99.9% or 3-logs, at the end of UV lamp life, which is two years of continuous operation.

Figure 2 below provides an indication of the UV dosage requirements in order to provide a 90-99% reduction in different strains of coronavirus.

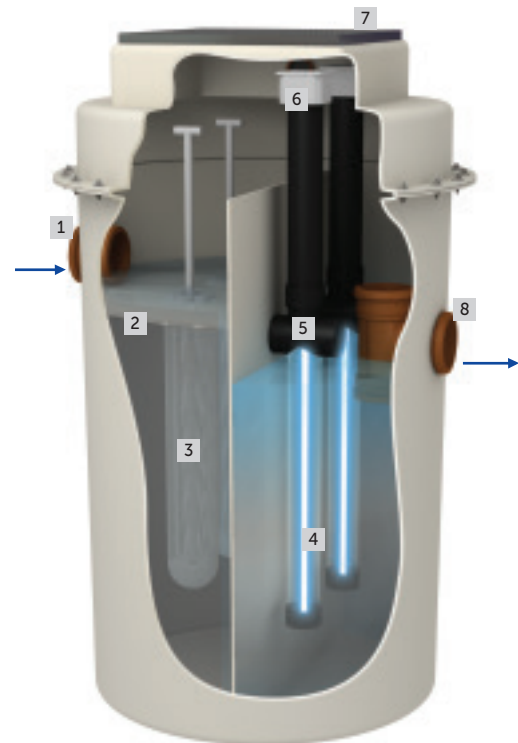

Key

- 1 Inlet
- 2 Filter shelf
- 3 Quick-release microfibre tertiary filters
- 4 UV lamps
- 5 Disinfection chamber
- 6 Control box
- 7 Maintenance access cover
- 8 Outlet

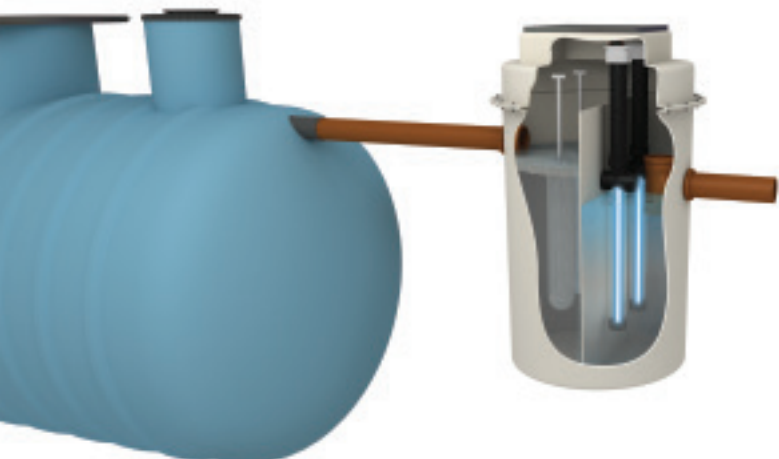

Benefits

- Removes 99% faecal coliform bacteria levels from sewage treatment plant effluent
- Optimum UV light distribution assembly for maximum disinfection (UV dosage requirements to provide a 90-99% reduction in different strains of coronavirus)
- Can be supplied as an integral part within the Marsh Ultra:Polylok range of sewage treatment plants (50-500+PE) or as a stand-alone unit
- Unique microfibre tertiary filters further reduce remaining suspended solids, residual biological oxygen demands and ammonia levels
- Optimised for minimal running costs
- Heavy duty shell as standard to enable installation in all ground conditions
- Integral eye bolts for improved on-site handling
- 'Keying-in flange' assists anchoring into granular or concrete surround
- Pedestrian cover included as standard

Modern sewage treatment plants are efficient systems used to process waste water from domestic or commercial premises to a standard that allows outflowing effluent to be discharged into natural bodies of water, such as drainage fields, streams, rivers or lakes.

The sewage treatment plant removes toxic constituents, such as suspended solids, nitrogen and ammonia, etc, however microscopic pathogens can remain undetected within the outflowing effluent. These pathogens are typically harmless, but the risk remains that some hazardous pathogens, such as coronaviruses, could survive and prosper in the natural environment.

As Covid-19 marches across the globe, public health, personal hygiene and sanitation is at the forefront of everyone's mind. Biologists, public health experts and researchers are exploring all possible routes of virus transmission, including the possibility of contamination from water and sewage.

Covid-19

Although it is not yet proven that Covid-19 can survive or spread through contact with water and sewage, environmental biologists at the University of Stirling have warned that the potential spread of Covid-19 via sewage "must not be neglected" in the battle to protect human health.

Richard Quilliam, Professor of Biological and Environmental Sciences at the University of Stirling, who is currently leading a £1.85m study into the transport of pathogens and viruses in marine environments, said "We know that Covid-19 is spread through droplets from coughs and sneezes, or via objects or materials that carry infection. However, it has recently been confirmed that the virus can also be found in human faeces up to 33 days after the patient has tested negative for symptoms of Covid-19."

"It is not yet known whether the virus can be transmitted via the faecal-oral route, however, we know that viral shedding from the digestive system can last longer than shedding from the respiratory tract. Therefore, this could be an important, but as yet unquantified, pathway for increased exposure."

The authors of the peer-reviewed paper presented the example of the severe acute respiratory syndrome (SARS) outbreak in 2002-2003 when SARS, closely linked to the Covid-19 virus strain, was detected in sewage discharged by two hospitals in China.

Professor Quilliam highlights that, as most Covid-19 patients are asymptomatic or experience just mild symptoms and remain at home (not in hospital), there is significant risk of "widespread" distribution through sewers.

UV dosage requirements to provide a 90-99% reduction in different strains of coronavirus (where historical data exists)

Organism	90% (1 log reduction) mJ/cm ²	99% (2 log reduction) mJ/cm ²	Source
Coronavirus	0.7	2.1	Walker 2007
Berne virus (Coronaviridae)	0.7	2.1	Weiss 1986
Murine Coronavirus (MHV)	1.5	4.5	Hirano 1978
Canine Coronavirus (CCV)	2.9	8.7	Saknimit 1988
Murine Coronavirus (MHV)	2.9	8.7	Saknimit 1988
SARS Coronavirus CoV-P9	4.0	12.0	Duan 2003
Murine Coronavirus (MHV)	10.3	30.9	Liu 2003
SARS Coronavirus (Hanoi)	13.4	40.2	Kariwa 2004
SARS Coronavirus (Urbani)	24.1	72.3	Walker 2007
Average	6.7	20.1	

In principle - The effects of UV light on bacteria

Bacteria, which causes some of our most common illnesses, are single cell organisms.



When looking inside a bacterium, the simplicity of the cell is evident; the cell contains DNA, ribosome and other basic proteins – this simplicity increases its susceptibility to UV light.

UV-induced DNA damage can affect how proteins and enzymes are produced. UV can also increase reactive oxygen species production, which can react with the cell wall. The cell wall and other components of the cell can become severely damaged, thus halting cell growth.

Effluent disinfection

For over a century scientists have known about the ability of ultraviolet light (UV) to disinfect and, for many years, UV-C2 lamps have been used for disinfection in medical settings, food production and a number of other places.

Effluent disinfection using UV light is the decontamination of outflowing water from sewage treatment plants, sewer pipes or industrial outfall into natural bodies of water.

Without UV disinfection, effluent can retain a mass of hazardous pathogens that could infect the natural water, causing potentially serious environmental health issues.

UV light deactivates pathogens so that they cannot survive in clean water, meaning they cannot replicate and infect future waterways.

UV light is one of the safest disinfectants available due to the lack of chemicals used and produced by the device.

The most common method of effluent disinfection used in off-mains sewage treatment plants is to install and connect a separate UV disinfection unit to the outlet of the sewage treatment plant.

The UV disinfection unit contains the necessary UV light system to match the volume of outflow from the sewage treatment plant.

It should be noted that when introducing a UV disinfection unit to a sewage treatment plant, it is necessary to ensure that the flow of water does not exceed the depth the UV light can travel. UV light can only pass through a certain amount of water before it becomes ineffective. Making sure that the water flow is uniform with the UV light means that the effluent will receive the best disinfection possible.

Notes:

¹ <https://www.stir.ac.uk/news/2020/05/sewage-poses-potential-covid-19-transmission-risk-experts-warn>

² UV-C refers to ultraviolet light with wavelengths between 200–280 nanometers (nm). Light in the UV-C wavelength can be used for disinfecting water, sterilizing surfaces, destroying harmful micro-organisms in food products and in air.

PUMP STATIONS

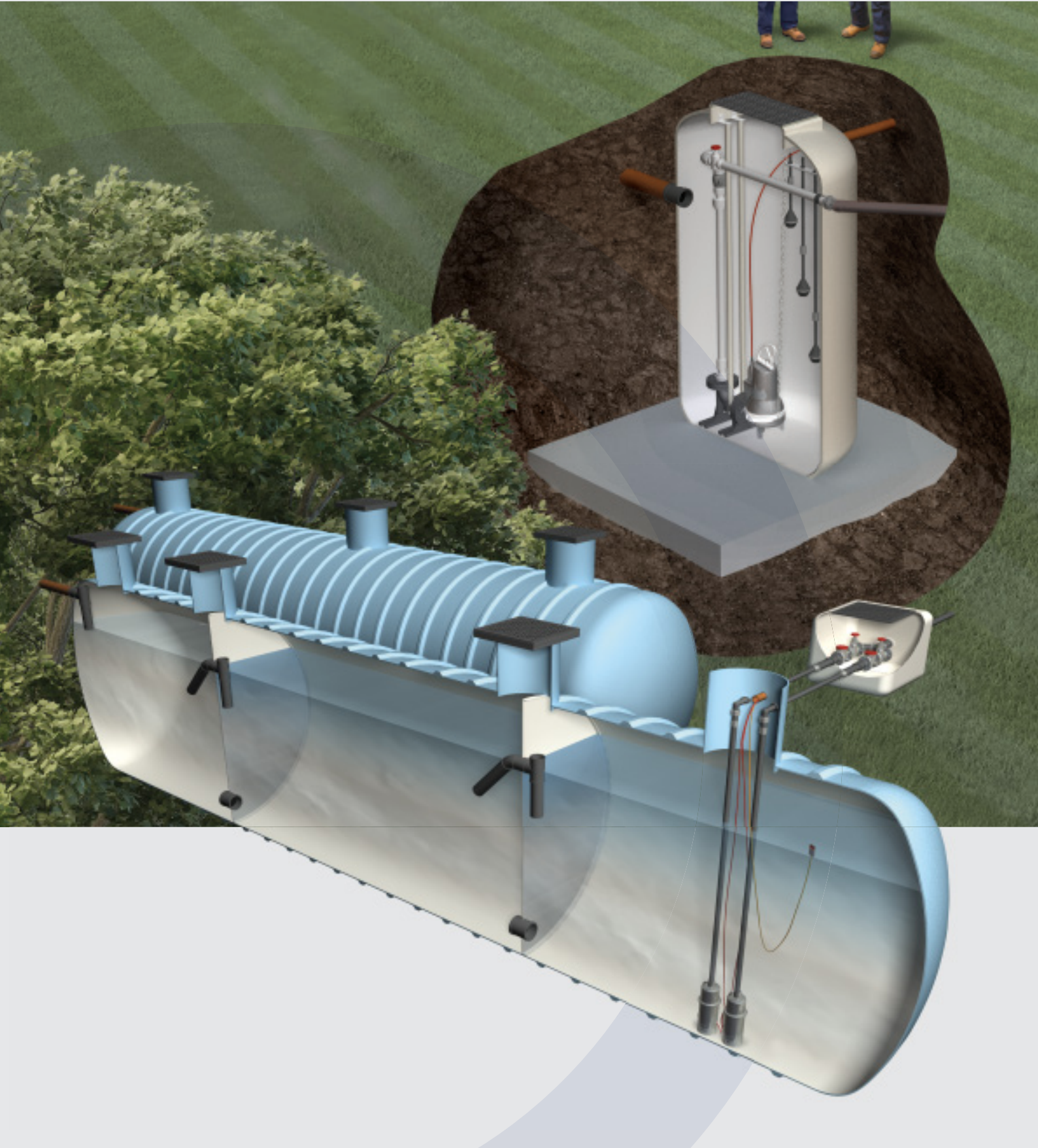

Marsh WellWater™

The most comprehensive range of pump stations available in the UK

Pump stations available in capacities ranging from 141 to 100,000 litres

When discharge to mains is required, but to do so by gravity is impractical, a WellWater™ pump station will be needed.

All Marsh pump station systems are bespoke, however there are several factors that play a role in identifying precisely the right tank sizes and type that are required for your project.

Marsh Civils' system designers can work closely with you to identify all key requirements in accompaniment with Marsh Industries' unique process design software, Gaia Sege.

Pump station systems are available as vertical or horizontal units in various sizes.

Why specify a Marsh pump station?

- Designed to British Standard European Norms:
 - BSEN12050 for structural strength and water-tightness*
 - BSEN752 to comply with hydrostatic and electrical requirements*
 - BSEN752-6 for drain and sewer systems in outside buildings*
- Smooth internal walls and integral pump well improve pump efficiency and eliminates 'dead spots' which can lead to odours and septicity
- Variable invert depths and orientations to suit individual site conditions
- Pre-assembled pipework for fully automatic operation
- Unique 'keying-in' lip on WellWater:Seine range assists anchoring into concrete surround

Pump options

Marsh uses market-leading submersible pumps throughout its WellWater range of pump stations to ensure maximum reliability and efficiency with minimal clogging or wear. Pump stations can be specified with a single free-standing pump or single and twin pumps with guide rails as illustrated below.

Note: Floats can be fitted directly to specific pump systems. please contact Marsh Civils to discuss your project requirements.



Single free-standing pump

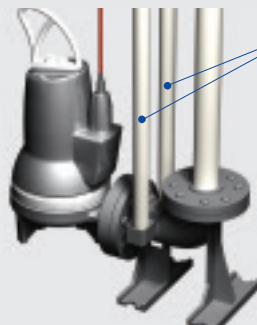

Single pump with guide rails

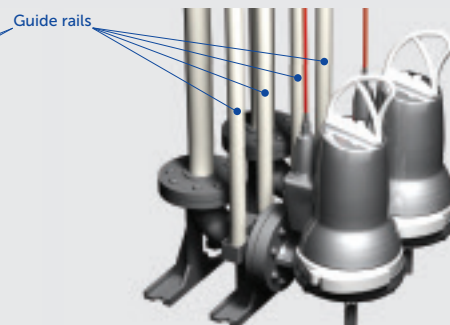

Twin pumps with guide rails

Applications

The WellWater range of pump stations are suitable for sewage, final effluent, grinders and surface water (twin/single) applications in all domestic, commercial and industrial sites:

- Agricultural water and wastewater
- Biofuel systems
- Commercial buildings
- Domestic buildings
- Food processing
- Industrial boilers
- Industrial wastewater
- Industrial water treatment
- Marine
- Mining
- Pharmaceuticals
- Wastewater transport
- Wastewater treatment
- Water distribution
- Water intake
- Water treatment

Pump station maintenance packages

Pump station maintenance packages provide peace of mind that your pump and associated equipment will continue to work reliably and effectively, whilst at the same time considerably extending their working-life expectancy.

Pump stations covered by Marsh maintenance packages suffer far fewer intermediate breakdowns, making scheduled maintenance an extremely cost-effective safeguard against potential failure.

For details on Marsh pump station maintenance packages contact 01933 829470 or email service@marshindustries.co.uk.

Guidance notes

- Where foul water drainage from a domestic property is to be pumped to mains the effluent receiving chamber should be sized to contain 24-hour inflow to allow for disruption in service, the minimum daily discharge being taken as 150 litres per person per day
- For other building types the capacity of the receiving chamber should be based on the calculated daily demand of the water intake for the building, or when only a proportion of the foul sewage is to be pumped then the capacity should be based pro-rata
- If the sewer is to be 'adopted' by a local water authority, please contact Marsh Civils as Sewers for Adoption (SFA) specification and additional local authority related criteria may apply

WellWater:Seine

Standard pump stations

Marsh WellWater:Seine pump stations are available in storage capacities ranging from 141 to 5675 litres.

Each system is supplied as a complete unit with either single or twin free-standing submersible pumps and high quality internal pipework/fittings as standard.

These pump stations are typically used in smaller domestic or commercial applications for pumping foul water or sewage to mains sewer.

Key

- 1 Inlet
- 2 Submersible pump(s)
- 3 Pump retrieval chain
- 4 Non-return valve(s)
- 5 Gate valve
- 6 Outlet connection
- 7 Ducting and cable entry points
- 8 Vent
- 9 Manway access
- 10 Float bracket

Float configuration options

- A Pump 'OFF' float switch
- B Pump 1 'ON' float switch
- C Pump 2 'ON' float switch
- D High water float switch



WellWater:Seine range

Model	Single/Twin pump	Pump duty <small>See table below</small>	Application <small>mm</small>	Diameter <small>mm</small>	Depth <small>mm</small>	Total storage <small>Litres</small>	Invert <small>mm</small>	Pipework dia
SE0610	Single	A	Effluent	600	1000	141	500	32
SE0615	Single	A	Effluent	600	1500	282	500	32
SE0620	Single	A	Effluent	600	2000	424	500	32
SE1111	Single	A	Effluent	1100	1100	570	500	32
TE1111	Twin	A	Effluent	1100	1100	570	500	32
SE1115	Single	A	Effluent	1100	1500	950	500	32
TE1115	Twin	A	Effluent	1100	1500	950	500	32
SE1122	Single	A	Effluent	1100	2200	1616	500	32
TE1122	Twin	A	Effluent	1100	2200	1616	500	32
SE1126	Single	A	Effluent	1100	2600	1996	500	32
TE1126	Twin	A	Effluent	1100	2600	1996	500	32
SS0610	Single	B	Sewage	600	1000	141	500	63
SS0615	Single	B	Sewage	600	1500	282	500	63
SS0620	Single	B	Sewage	600	2000	424	500	63
SS1111	Single	B	Sewage	1100	1100	570	500	63
TS1111	Twin	B	Sewage	1100	1100	570	500	63
SS1115	Single	B	Sewage	1100	1500	950	500	63
TS1115	Twin	B	Sewage	1100	1500	950	500	63
SS1122	Single	B	Sewage	1100	2200	1616	500	63
TS1122	Twin	B	Sewage	1100	2200	1616	500	63
SS1126	Single	B	Sewage	1100	2600	1996	500	63
TS1126	Twin	B	Sewage	1100	2600	1996	500	63
TS1721	Twin	C	Sewage	1700	2100	2724	500	63/90
TS1734	Twin	D	Sewage	1700	3400	5675	500	90

Pump duties	Total lift m	1	2	3	4	5	6	7	8
A Effluent pumping stations	Distance m	54	43	30	20	8	-	-	-
B Up to TS1126 - 6m total head	Distance m	160	120	90	40	10	-	-	-
C TS1721 - 10m Total Head	Distance m	-	700	620	530	430	340	250	160
D TS1734 - 7.4m Total Head	Distance m	-	-	180	120	90	50	5	-

Notes:

- > Floats can be fitted directly to specific pump systems. please contact Marsh Civils to discuss your project requirements
- > All pump stations are available for dirty water (DW) or sewage (SW), in single pump (SP) and twin pump (TP) configurations
- > The dimensions given on this page are for guidance only
- > For precise tank sizes and configurations, please contact Marsh Civils
- > All dimensions in mm

Tank configurations and components are shown for illustration purposes only

WellWater:Hudson

Ø1.2-1.5m pump stations

Marsh WellWater:Hudson pump stations are Ø1.2m or Ø1.5m vertical units, available from 2000mm to 3500mm heights with storage capacities ranging from 2170 litres to 5979 litres.

Each system is supplied as a complete unit with either single or twin submersible pumps with guide rails and high quality internal pipework/fittings as standard.

These pump stations are typically used in medium to large domestic or commercial applications for pumping foul water or sewage to mains sewer.

Key

- 1 Inlet
- 2 Submersible pump(s)
Single or twin pumps with guide rails
- 3 Guide rails
- 4 Pump retrieval chain
- 5 Non-return valve(s)
- 6 Gate valve
- 7 Outlet connection
- 8 Ducting and cable entry points
- 9 Vent
- 10 Manway access
- 11 Float bracket

Float configuration options

- A Pump 'OFF' float switch
- B Pump 1 'ON' float switch
- C Pump 2 'ON' float switch
On twin pump configurations
- D High water float switch

*Note: Floats can be fitted directly to specific pump systems.
Please contact Marsh Civils to discuss your project requirements.*



WellWater:Hudson Ø1.2m range

Model	Single/Twin pump	Application	Diameter mm	Depth mm	Total storage Litres	Invert mm	Pipework dia mm
SS1220	Single	Sewage	1200	2000	2170	minimum 500	110 or 160
TS1220	Twin	Sewage	1200	2000	2170	minimum 500	110 or 160
SS1230	Single	Sewage	1200	3000	3300	minimum 500	110 or 160
TS1230	Twin	Sewage	1200	3000	3300	minimum 500	110 or 160
SS1235	Single	Sewage	1200	3500	3860	minimum 500	110 or 160
TS1235	Twin	Sewage	1200	3500	3860	minimum 500	110 or 160
SG1220	Single	Grinders	1200	2000	2170	minimum 500	110 or 160
TG1220	Twin	Grinders	1200	2000	2170	minimum 500	110 or 160
SG1230	Single	Grinders	1200	3000	3300	minimum 500	110 or 160
TG1230	Twin	Grinders	1200	3000	3300	minimum 500	110 or 160
SG1235	Single	Grinders	1200	3500	3860	minimum 500	110 or 160
TG1235	Twin	Grinders	1200	3500	3860	minimum 500	110 or 160

WellWater:Hudson Ø1.5m range

Model	Single/Twin pump	Application	Diameter mm	Depth mm	Total storage Litres	Invert mm	Pipework dia mm
SS1520	Single	Sewage	1500	2000	3328	minimum 500	110 or 160
TS1520	Twin	Sewage	1500	2000	3328	minimum 500	110 or 160
SS1530	Single	Sewage	1500	3000	5095	minimum 500	110 or 160
TS1530	Twin	Sewage	1500	3000	5095	minimum 500	110 or 160
SS1535	Single	Sewage	1500	3500	5979	minimum 500	110 or 160
TS1535	Twin	Sewage	1500	3500	5979	minimum 500	110 or 160
SG1520	Single	Grinders	1500	2000	3328	minimum 500	110 or 160
TG1520	Twin	Grinders	1500	2000	3328	minimum 500	110 or 160
SG1530	Single	Grinders	1500	3000	5095	minimum 500	110 or 160
TG1530	Twin	Grinders	1500	3000	5095	minimum 500	110 or 160
SG1535	Single	Grinders	1500	3500	5979	minimum 500	110 or 160
TG1535	Twin	Grinders	1500	3500	5979	minimum 500	110 or 160

More tank depths available upon request

WellWater:Nile

Ø1.8m pump stations

Marsh WellWater:Nile pump stations are Ø1.8m vertical units, available in 3000mm and 4000mm heights with storage capacities of 7250 litres and 9800 litres respectively.

Each system is supplied as a complete unit with either single or twin submersible pumps with guide rails and high quality internal pipework/fittings as standard.

These pump stations are typically used in large domestic or commercial applications for pumping foul water or sewage to mains sewer.

Key

- 1 Inlet
- 2 Submersible pump(s)
Single or twin pumps with guide rails
- 3 Guide rails
- 4 Pump retrieval chain
- 5 Non-return valve(s)
- 6 Gate valve
- 7 Outlet connection
- 8 Ducting and cable entry points
- 9 Vent
- 10 Manway access
- 11 Float bracket



Float configuration

options

- A Pump 'OFF' float switch
 - B Pump 1 'ON' float switch
 - C Pump 2 'ON' float switch
 - D High water float switch
- On twin pump config's*

Note: Floats can be fitted directly to specific pump systems. please contact Marsh Civils to discuss your project requirements.

WellWater:Nile range

Model	Single/Twin pump	Application	Diameter mm	Depth mm	Total storage Litres	Invert mm	Pipework dia mm
SS1830	Single	Sewage	1800	3000	7250	minimum 500	110 or 160
TS1830	Twin	Sewage	1800	3000	7250	minimum 500	110 or 160
SS1840	Single	Sewage	1800	4000	9800	minimum 500	110 or 160
TS1840	Twin	Sewage	1800	4000	9800	minimum 500	110 or 160
SG1830	Single	Grinders	1800	3000	7250	minimum 500	110 or 160
TG1830	Twin	Grinders	1800	3000	7250	minimum 500	110 or 160
SG1840	Single	Grinders	1800	4000	9800	minimum 500	110 or 160
TG1840	Twin	Grinders	1800	4000	9800	minimum 500	110 or 160

Notes:

- > All pump stations are available for dirty water (DW) or sewage (SW), in single pump (SP) and twin pump (TP) configurations
- > The dimensions given on this page are for guidance only
- > For precise tank sizes and configurations, please contact Marsh Civils
- > All dimensions in mm

Tank configurations and components are shown for illustration purposes only

WellWater:Amazon

Ø2.5m pump stations

Marsh WellWaterAmazon pump stations are Ø2.5m horizontal units, available in storage capacities ranging from 7710 litres to 100,000 litres.

Each system is supplied as a complete unit with either twin submersible pumps with guide rails and high quality internal pipework/fittings as standard.

These pump stations are typically used in extra large domestic or commercial applications for pumping foul water or sewage to mains sewer.

Key

- 1 Inlet
- 2 Twin pumps with guide rails
- 3 Guide rails
- 4 Pump retrieval chain
- 5 Non-return valve(s)
- 6 Gate valve
- 7 Outlet connection
- 8 Ducting and cable entry points
- 9 Vent
- 10 Manway access
- 11 Float bracket

Float configuration options

- A Pump 'OFF' float switch
- B Pump 1 'ON' float switch
- C Pump 2 'ON' float switch
- D On twin pump configurations High water float switch

Note: Floats can be fitted directly to specific pump systems. please contact Marsh Civils to discuss your project requirements.

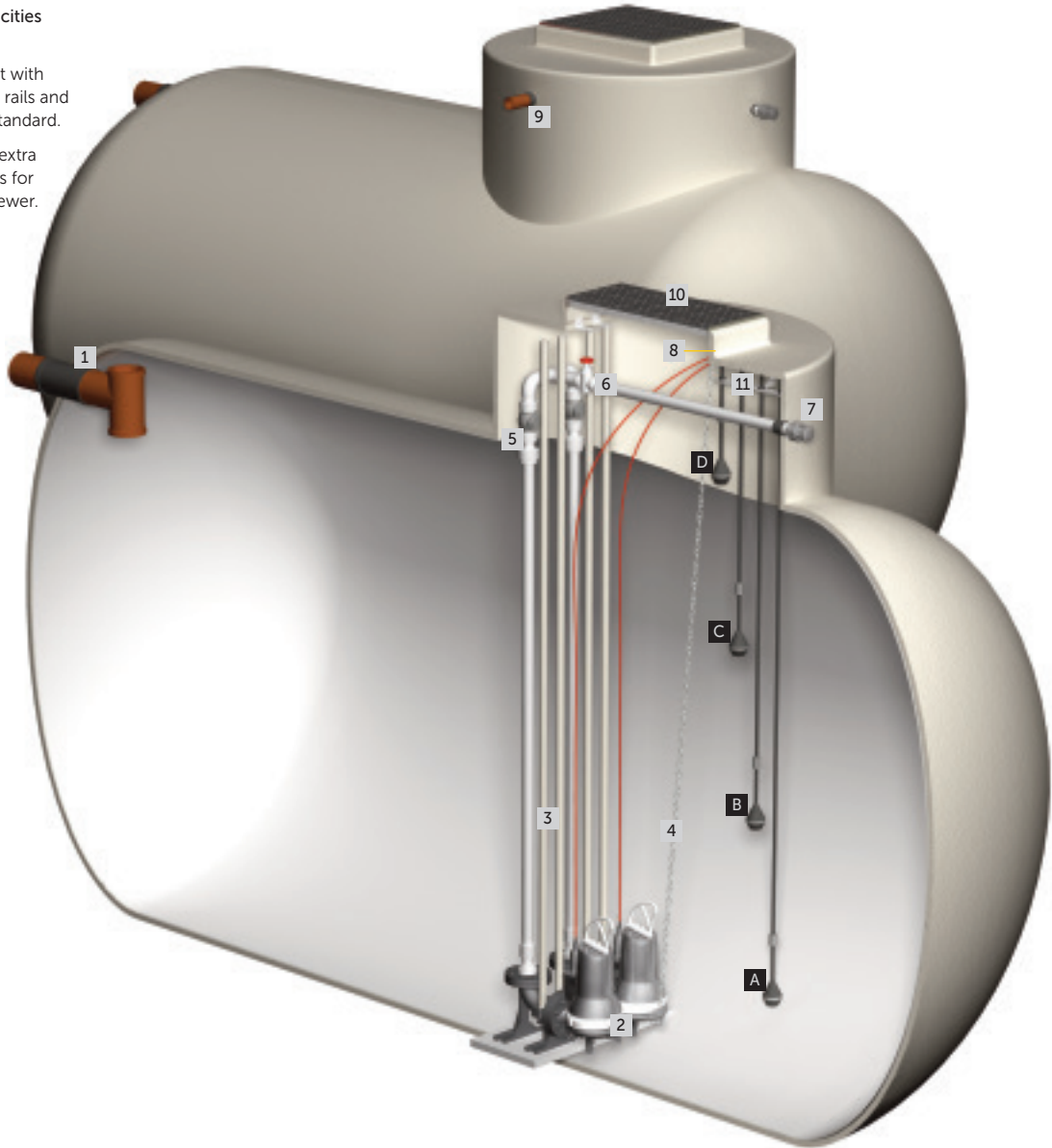

WellWater:Amazon range examples (Tanks with capacities up to 100,000 litres are available on request)

Model	Pump	Application	Diameter mm	Length mm	Total storage Litres	Invert mm	Pipework dia mm
TS2520	Twin	Sewage	2500	2000	7710	minimum 500	110 or 160
TS2535	Twin	Sewage	2500	3500	15050	minimum 500	110 or 160
TS2540	Twin	Sewage	2500	4000	17500	minimum 500	110 or 160

- Notes:**
- > All pump stations are available for dirty water (DW) or sewage (SW), in single pump (SP) and twin pump (TP) configurations
 - > The dimensions given on this page are for guidance only
 - > For precise tank sizes and configurations, please contact Marsh Civils
 - > All dimensions in mm

Tank configurations and components are shown for illustration purposes only

BASE2DRAIN

Basement pumps

Quality, efficiency, reliability

Introducing **BASE2DRAIN**; the safest, most reliable and efficient range of basement pumps from Marsh Industries.

Suitable for virtually all subterranean sites, Marsh **BASE2DRAIN** systems are designed in accordance with British Standard European Norms:

BSEN12050, BSEN752, BSEN752-6 and also carry third party approval for material fire safety and structural integrity.



Variable invert depths and orientations to suit individual site conditions

Smooth internal walls improve pump efficiency and eliminates 'dead spots' which can lead to odours and septicity

Structurally robust, fire tested GRP shell

Unique 'keying-in' lip assists anchoring into concrete surround



Reliable product, prompt response on after sales issues, and flexible delivery schedules when required.

– Client testimonial



Overview

A Marsh BASE2DRAIN basement pump is necessary when discharge from a subterranean site, such as an underground car park or a home basement, is required but gravity discharge is impractical.

Available in a wide range of sizes and capacities, all BASE2DRAIN systems are supplied as a complete unit with either twin or triple submersible pumps and high quality internal pipework/fittings as standard.

Marsh Civils' technical team can work closely with you to identify all key requirements in specifying the right system for your project.

Pump options

Marsh uses market-leading submersible pumps throughout its BASE2DRAIN range to ensure maximum reliability and efficiency with minimal clogging or wear.

Notes:

- > In triple submersible pump applications, one pump is typically used as a backup.
- > Floats can be fitted directly to specific pump systems

Specifications

Model	Pump options	Diameter +/-50mm	Depth +/-50mm	Total storage Litres	Outlet diameter	Outlet invert	Power
B2D-TP675	Twin pump	600mm	750mm	141 Litres	32mm MDPE	250mm	0.25kw/0.55kw
B2D-TP610	Twin pump	600mm	1000mm	169 Litres	32mm MDPE	400mm	0.25kw/0.55kw
B2D-TP615	Twin pump	600mm	1500mm	212 Litres	32mm MDPE	750mm	0.55kw
B2D-TP620	Twin pump	600mm	2000mm	226 Litres	32mm MDPE	1200mm	0.55kw
B2D-TRP7575/BB	Twin pump / Triple pump / UPS battery-back up options	750mm	750mm	220 Litres	32mm MDPE	250mm	0.25kw/0.55kw
B2D-TRP7510	Twin pump / Triple pump options	750mm	1000mm	265 Litres	32mm MDPE	400mm	0.25kw/0.55kw
B2D-TRP7515	Twin pump / Triple pump options	750mm	1500mm	331 Litres	32mm MDPE	750mm	0.55kw
B2D-TRP7520	Twin pump / Triple pump options	750mm	2000mm	353 Litres	32mm MDPE	1200mm	0.55kw

Notes:

- > The dimensions given on this page are for guidance only
- > For precise tank sizes and configurations, please contact Marsh
- > All dimensions in mm



Why specify Marsh?

- 🔗 Designed to British Standard European Norms:
 - BSEN12050 for structural strength and water-tightness
 - BSEN752 to comply with hydrostatic and electrical requirements
 - BSEN752-6 for drain and sewer systems in outside buildings
- 🔗 Smooth internal walls and integral pump well improve pump efficiency and eliminates 'dead spots' which can lead to odours and septicity
- 🔗 Variable invert depths and orientations to suit individual site conditions
- 🔗 Pre-assembled pipework for fully automatic operation
- 🔗 Unique 'keying-in' lip assists anchoring into concrete surround
- 🔗 GRP tank material passed all practical fire testing to achieve EN ISO 11925-2:2010 standard (see back page)
- 🔗 Structural integrity tests performed in accordance with EN ISO 179-1/1eA: 2010-11 (see back page)

Note: Tank products and configurations shown for illustrative purposes only

OIL SEPARATORS



SuDS SAFE
SEPARATORS



Speaking to experts in their field, such as those at Marsh Industries, provides us with confidence that the correctly sized tank is supplied and installed. Their systems are innovative and generally on quick lead times.

– Client testimonial

Separation by flotation and settlement

Oil separators are designed to prevent oil and other hydrocarbons from entering the drainage system. They separate oil from water, and safely retain the oil until it is removed.

Oil cannot be treated easily and will therefore cause severe pollution if allowed to enter mains sewers or drainage fields. Statutory controls enforce strict regulations on the discharge of such pollutants.

Separators should be used in such applications as petrol stations, industrial yards and garages; or virtually anywhere that a risk of oil contamination exists.

Discharge requirements for oil separators may vary in different areas of the country and it is therefore essential to consult the appropriate environmental controlling authority prior to specifying an oil separator. If the discharge is to a public sewer then local Building Control, the Water Authorities and water companies should also be contacted.

Note: For larger sites, more than one type of oil separator may be required.

Separator types and principles of operation

Classes

Separators are classed in two categories based on performance under standard test conditions.

Class 1 separators are designed to achieve a discharge concentration of less than 5mg/litre of oil. These separators are required for discharges to surface water drains and the water environment.

Class 2 separators are designed to achieve a discharge concentration of less than 100mg/litre of oil under standard test conditions. They are suitable for dealing with discharges where there is a lower quality requirement, such as discharges to the foul sewer.

Both classes can be produced as 'full retention', 'bypass' or 'forecourt' separators as explained below.

Bypass separators

Bypass separators treat all flows from rainfall events of up to 6.5mm/hr. This covers over 99% of all rainfall events. Flows higher than 6.5mm/hr are designed to bypass the separator.

These separators are used in a 'low risk' environment where there is no requirement to provide full treatment for the flow; for example a car park where the risk of a significant spillage is small.

Full retention separators

Full retention separators treat the full flow that is delivered by the drainage system, which is normally equivalent to the flow generated by a rainfall intensity of 65mm/hr.

These separators are used where there may be a 'high risk' of a significant fuel spillage, such as vehicle workshops

Forecourt separators

Forecourt separators are a type of full retention separator, however they are specifically designed to store the maximum spillage likely to occur on a petrol station forecourt.

These separators are manufactured to a specific size in order to retain the potential spillage from a single compartment of a road tanker – currently up to 7,600 litres in the UK.

Wash-down separators and silt traps

It is a legal requirement to install a silt trap or wash-down separator on commercial sites, such as vehicle wash bays, where there is an environmental risk of contamination from dirt, brake dust, traffic film residue, cleaning agents, oil, etc.

Choosing the right separator

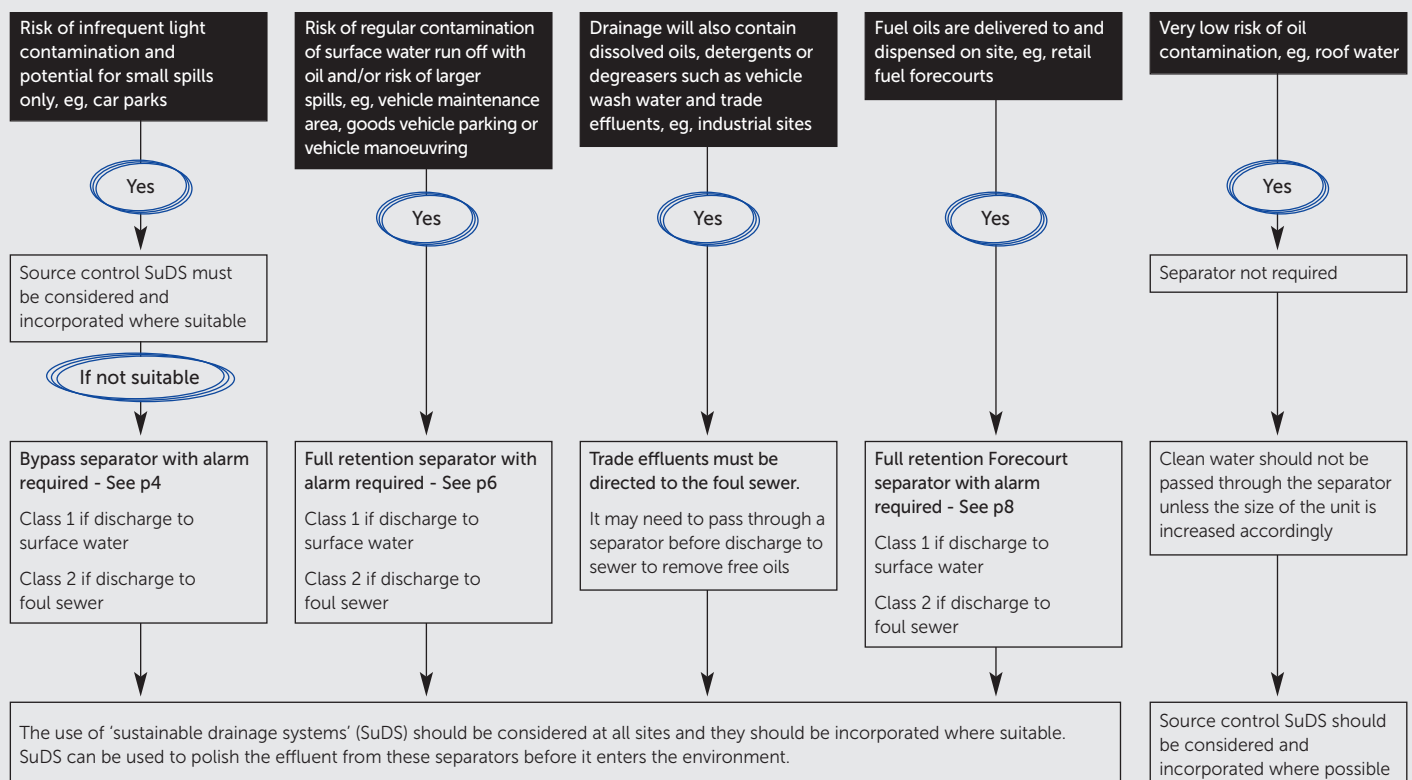

Marsh:Marator™

High performance full retention oil separators for sites where the “industry standard” is just not good enough

Overview

Marsh Industries has developed an innovative separator system that breaks the constraints of the current standards; the 'Marsh:Marator'.

The Marator takes advantage of nanofiltration technology to produce discharge that is 50 times better than any current separator available on the market today; that is less than 0.1mg/ltr – the standard only requires less than 5mg/ltr for a 'class 1 discharge'.

Testing was analysed for hydrocarbon content using infrared spectroscopy at GEOTAIX UMWELTECHNOLOGIE GmbHA.

During the sampling period, five samples of 500ml were taken via the sampling point. The quality of discharge from the Marator exceeded the measureable level of the test equipment not to mention the current EN standard:

Test results (NS6 model)

Sample	Result GC in mg/litre (Industry standard <5mg/litre)
NS 6-1	< 0.1
NS 6-2	< 0.1
NS 6-3	< 0.1
NS 6-4	< 0.1
NS 6-5	< 0.1
NS 6-6	< 0.1
NS 6-7	< 0.1
Average	< 0.1

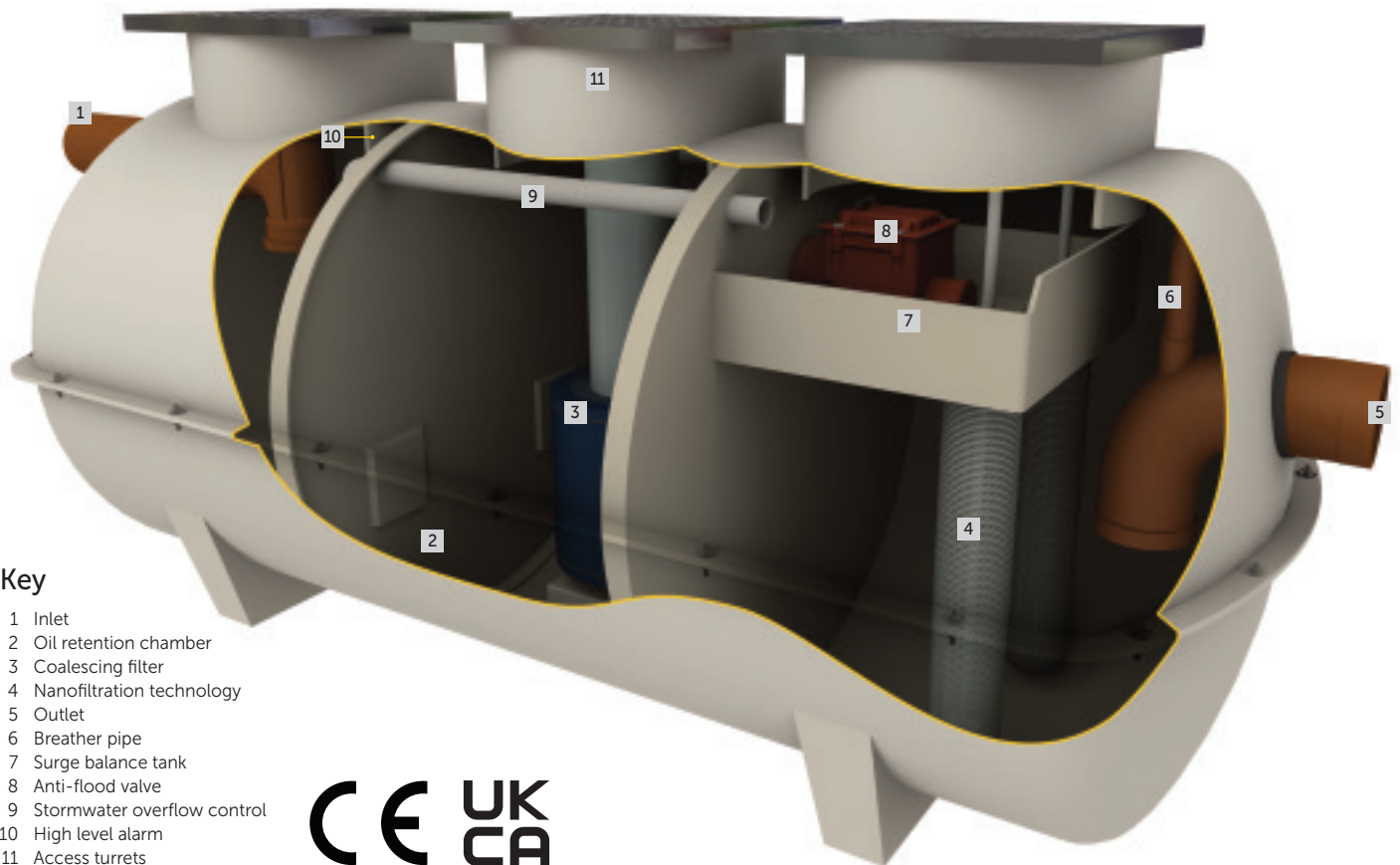

Key

- 1 Inlet
- 2 Oil retention chamber
- 3 Coalescing filter
- 4 Nanofiltration technology
- 5 Outlet
- 6 Breather pipe
- 7 Surge balance tank
- 8 Anti-flood valve
- 9 Stormwater overflow control
- 10 High level alarm
- 11 Access turrets



Benefits

- Designed and tested to meet latest UK and European standards
- Corrosion resistant
- Tank shells guaranteed for 25 years with a design life of 50 years
- Heavy duty shells enable installation in all ground conditions
- Easy access turrets for maintenance and servicing (Turret guards optional)
- Various alarm types available (Required by EN858-1)
- Variable invert depths and inlet/outlet configurations to suit individual site conditions
- Vented turrets can dissipate excessive fumes and vapours

Typical applications

- Car parks
- Roadways
- Industrial estates
- Vehicle workshops
- Refuel facilities
- Fuel storage sites

Illustration shown for visual reference only



Specifications

Ground level

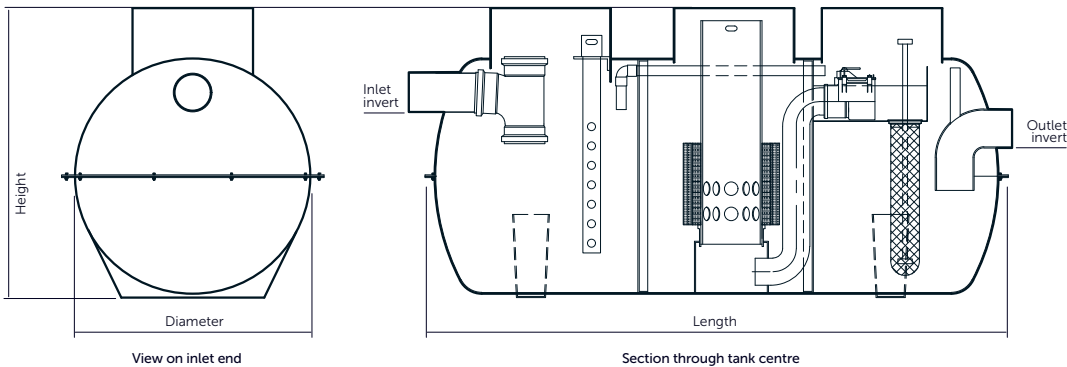

Model	Max flow litre/sec	Drainage area m ²	Silt storage litres	Oil storage litres	Diameter +/-50mm	Length +/-50mm	Height +/-50mm	Connection size	Inlet invert	Outlet invert
Marator 6	6	340	600	60	1250	3040	1862	200	900	1100
Marator 10	10	566	1000	100	1250	4040	1862	200	900	1100
Marator 15	15	851	1500	150	1812	4240	2360	315	900	1100
Marator 20	20	1137	2000	200	1812	4240	2360	315	900	1100

Notes:

- > Larger systems are available, please contact Marsh Civils
- > The dimensions given on this page are for guidance only
- > For precise tank sizes and configurations, please contact Marsh Civils
- > Number of access shafts will be built to suit site specifications and to maintain safe access for emptying
- > All dimensions in mm

Are outmoded EN standards an environmental concern?

Current EN standard

The European Standard, BS EN 858 parts 1&2, was introduced in 2002 to normalise design and regulate testing of products across Europe. This standard settled on a two-tier quality level – class 1 and class 2.

Class 1 – designed to achieve a discharge concentration of less than 5mg/ltr of oil in the discharge

Class 2 – designed to achieve a discharge concentration of less than 100mg/ltr of oil in the discharge

Once testing is complete and approval achieved, manufacturers are free to bring their products to market.

The effects of current standards

A good starting point for any product is to set out relevant standards and levels of quality, both in product build and product performance. However, since the introduction of BS EN 858 in 2002, product development in gravity oil/liquid separation has remained static.

Manufacturers are only required to meet the testing standards to sell product. There has been no natural drive to improve product performance.

The current class 1 standard of less than 5mg/ltr of light liquid is only determined by test conditions. Our experience in this field tells us that this standard is rarely met once a product is installed.

The reality of current standards

With the current level of 5mg/ltr for a Class 1 discharge – we ask “Are Class 1 separators the very best that manufacturers can offer?”

Studies have shown that the majority of hydrocarbon pollutants entering the water system stems from urban developments. Figure 2 shows the toxic effects of particular contaminants on humans and aquatic life.

Leaving aside the toxic effects of contaminants on human and aquatic life, when a hydrocarbon molecule spreads to one molecule thick and given enough surface area to spread, five litres of oil would be more than enough to contaminate five football pitches.

In addition, most hydrocarbon molecules are attached to silt particles; where Stokes’ law proves that these particles will sink rather than float as conventional separators require.

When mixed with other elements in real life scenarios, such as glycol, standard gravity separators become less efficient at contaminant removal.

In our view, the current testing standards covering products within the gravity separator market are outmoded and failing to protect the environment as they should. They do not reflect or address any ‘real-life’ scenario where hydrocarbon pollution is prevalent.

The solution = the Marsh:Marator

Marsh:Hydroil™

Full retention separators

For areas at 'high risk' of oil contamination

Overview

Full retention separators are used where there may be a 'high risk' of a significant fuel spillage, such as vehicle workshops

Designed and tested to BS EN858 parts 1&2, Marsh Hydroil full retention separators are manufactured from virgin unfilled resin offering exceptional durability, impact resistance and are guaranteed to be watertight and of uniform thickness. These combined properties ensure that the full range of separators stand up to the most rigorous conditions during their service life.

Internal working components, such as coalescing filters, automatic closure devices, weirs, oil skimmer plates, and their configurations offer the most modern and efficient oil/water separation capability available to the market today.

A wide choice of inlet and outlet positions are available on the units - detailed requirements should be provided at time of order (standard inlet and outlet positions will otherwise be fitted).

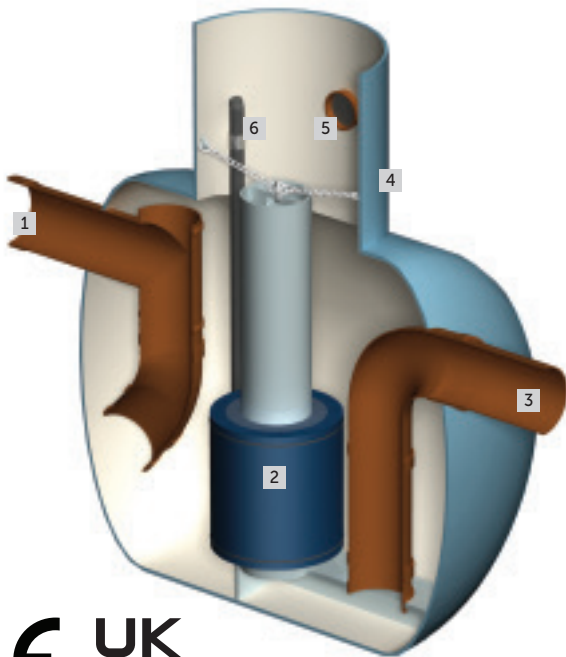

Operating principle

Marsh Hydroil full-retention separators treat the full flow that is delivered by the drainage system, which is normally equivalent to the flow generated by a rainfall intensity of 65mm/hr.

Key

- 1 Inlet
- 2 Coalescer
- 3 Outlet
- 4 Access turret
- 5 Air vent
- 6 Level alarm dip pipe

Flowpath

- ➔ Oil/water mixture
➔ Water

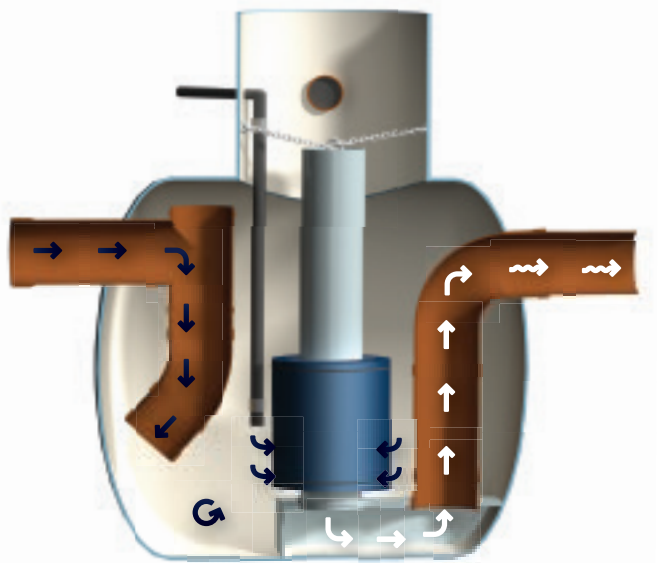

Benefits

- Designed and tested to meet latest UK and European standards
- Corrosion resistant
- Tank shells guaranteed for 25 years with a design life of 50 years
- Heavy duty shells enable installation in all ground conditions
- Easy access turrets for maintenance and servicing (Turret guards optional)
- Various alarm types available (Required by EN858-1)
- Variable invert depths and inlet/outlet configurations to suit individual site conditions
- Vented turrets dissipate excessive fumes and vapours

Typical applications

- Vehicle workshops
- Refuel facilities
- Fuel storage sites

Mitigation indices

As the world focuses on more green and environmentally friendly solutions, Marsh Industries has examined how effective their separators are when incorporating them into sustainable drainage schemes.

The company tested their full retention Hydroil separator range for total suspended solids and metal mitigation indices in line with industry-approved procedures at PIA, the notified test house in Aachen, Germany. This is in addition to an existing test procedure, whereby the Hydroil has already achieved EN858-1 certification for light liquid separators.

Combining these two test sets together and applying the simple index approach to proprietary/manufactured EN858 devices, the Hydroil separator range is able to achieve the following mitigation indices:

Hydrocarbons: 97.5%
Total Suspended Solids: 84.35%
Total Metal Reduction: 63.26%

The results will provide user confidence that the testing of this range is beyond reproach and cements these products as the complete surface water treatment solution for SuDS schemes.



Specifications

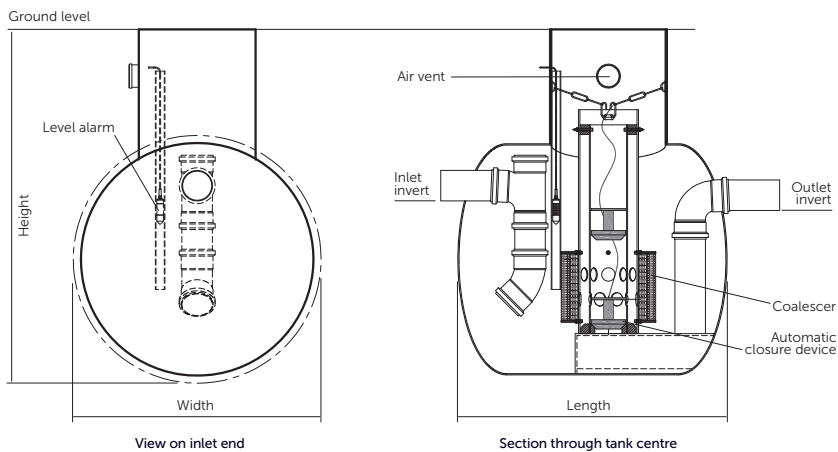

Full retention separator range

Model	Flow litre/sec	Drainage area m ²	Silt storage litres	Oil storage litres	Width +/-50mm	Length +/-50mm	Height +/-50mm	Connection size	Inlet invert	Outlet invert
NSFR 3	3	170	300	30	1200	1400	1840	160	900	950
NSFR 4	4.5	255	450	40	1200	1700	1840	160	900	950
NSFR 6	6	340	600	60	1200	2400	1840	160	900	950
NSFR 8	8	453	800	80	1200	3200	1840	160	900	950
NSFR 10	10	566	1000	100	1200	3500	1840	160	900	950
NSFR 15	15	851	1500	150	1800	3600	2440	200	900	1000
NSFR 20	20	1137	2000	200	1800	4000	2440	200	900	1000
NSFR 30	30	1700	3000	300	1800	4800	2440	250	900	1000
NSFR 40	40	2265	4000	400	1800	6200	2440	315	900	1000
NSFR 50	50	2800	5000	500	1800	7500	2440	315	900	1000
NSFR 60	60	3233	6000	600	2622	5200	3172	315	900	1000
NSFR 65	65	3670	6500	650	2622	5600	3172	315	900	1000
NSFR 70	70	4318	7000	700	2622	6000	3172	315	900	1000
NSFR 80	80	4533	8000	800	2622	6600	3172	315	900	1000
NSFR 100	100	5666	10000	1000	2622	8600	3172	315	900	1000
NSFR 125	125	7082	12500	1250	3128	7200	3678	400	900	1100
NSFR 150	150	8500	15000	1500	3128	8400	3678	400	900	1100
NSFR 165	165	9166	16500	1650	3128	9300	3678	400	900	1100
NSFR 175	175	9800	17500	1750	3128	10000	3678	400	900	1100
NSFR 200	200	11110	20000	2000	3128	11300	3678	400	900	1100
NSFR 210	210	11898	21000	2100	3128	11500	3678	400	900	1100
NSFR 250	250	13888	25000	2500	3128	13800	3678	400	900	1100
NSFR 275	275	15582	27500	2750	3128	14500	3678	400	900	1100

Notes:

- > The dimensions given on this page are for guidance only
- > For precise tank sizes and configurations, please contact Marsh Civils
- > Number of access shafts will be built to suit site specifications and to maintain safe access for emptying
- > All dimensions in mm

Marsh:Hydroil™ Bypass separators

For areas at 'low risk' of oil contamination

Overview

Bypass separators are used in a 'low risk' environment where there is no requirement to provide full treatment for the flow: for example a car park where the risk of a significant spillage is small.

Designed and tested to BS EN858 parts 1&2, Marsh Hydroil bypass separators are manufactured from virgin unfilled resin offering exceptional durability, impact resistance and are guaranteed to be watertight and of uniform thickness. These combined properties ensure that the full range of separators stand up to the most rigorous conditions during their service life.

Internal working components, such as coalescing filters, weirs, oil skimmer plates, and their configurations offer the most modern and efficient oil/water separation capability available to the market today.

A wide choice of inlet and outlet positions are available on the units - detailed requirements should be provided at time of order (standard inlet and outlet positions will otherwise be fitted).

Operating principle

Marsh Hydroil bypass separators are designed to treat 10% of peak flow.

The drainage areas served by each separator are determined in accordance with both BS EN858 parts 1&2, but also with reference to a formula provided by the Environment Agency, where $NSB=0.0018xA$ (catchment area in m^2). Flows from higher rainfall rates are allowed to bypass the main separation chamber.

Key

- 1 Inlet
- 2 Oil skimmer plate
- 3 Coalescer
- 4 Outlet
- 5 Access turret
- 6 Level alarm dip pipe
- 7 Air vent

Flowpath

- ➔ Oil/water mixture
➔ Water

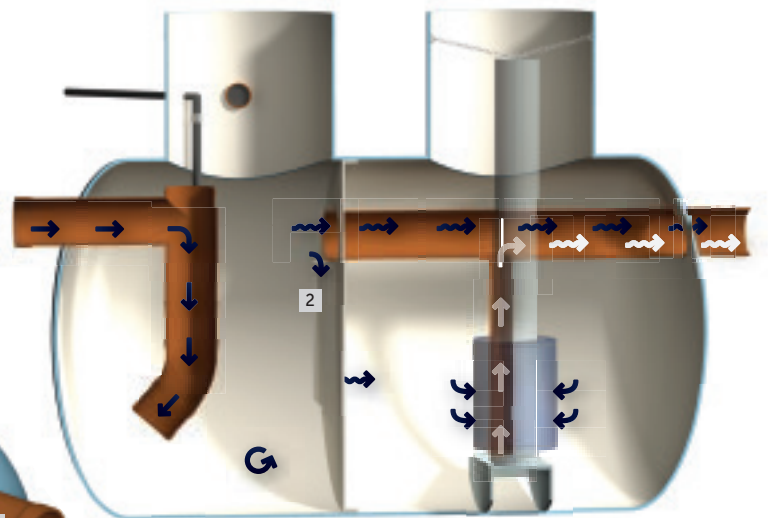
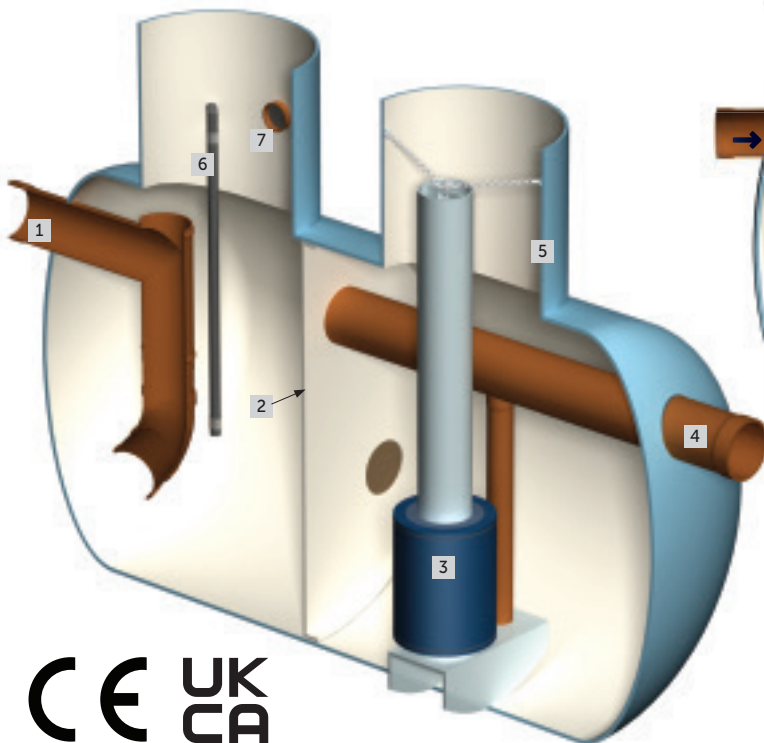

Benefits

- Designed and tested to meet latest UK and European standards
- Corrosion resistant
- Tank shells guaranteed for 25 years with a design life of 50 years
- Heavy duty shells enable installation in all ground conditions
- Easy access turrets for maintenance and servicing (Turret guards optional)
- Various alarm types available (Required by EN858-1)
- Variable invert depths and inlet/outlet configurations to suit individual site conditions
- Vented turrets dissipate excessive fumes and vapours

Typical applications

- Car parks
- Roadways
- Industrial estates
- SuDS

Specifications

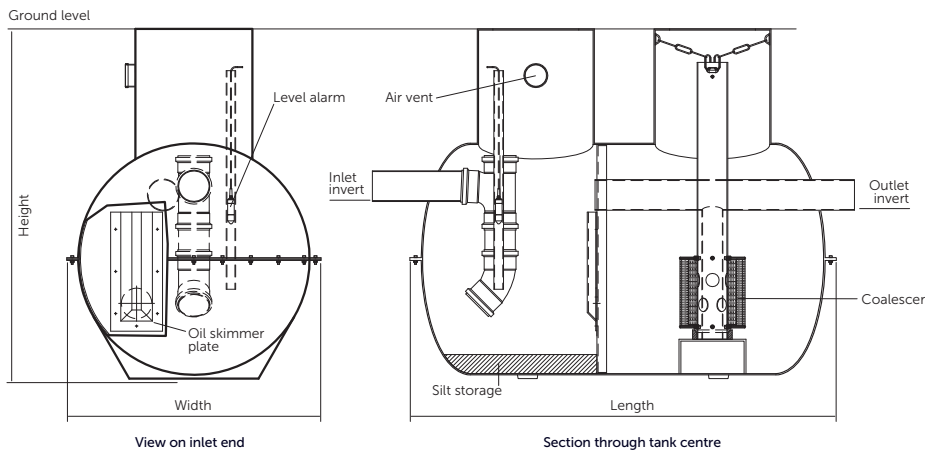

Bypass separator range

00 Model	Flow litre/sec	Drainage area m ²	Silt storage litres	Oil storage litres	Width +/-50mm	Length +/-50mm	Height +/-50mm	Connection size Ø	Inlet invert	Outlet invert
NSBP 3	30	1700	300	45	1354	2254	1834	160 O/D	900	950
NSBP 4	45	2550	450	67.5	1354	2254	1834	160 O/D	900	950
NSBP 6	60	3400	600	90	1354	2254	1784	200 O/D	900	950
NSBP 8	80	4530	800	120	1354	2254	1784	200 O/D	900	950
NSBP 10	100	5660	1000	150	1354	2914	1784	315 O/D	900	950
NSBP 15	150	8510	1500	225	1354	4184	1784	315 O/D	900	1000
NSBP 18	180	10198	1800	270	1818	2398	2418	400 O/D	1050	1150
NSBP 20	200	11370	2000	300	1818	2398	2418	400 O/D	1050	1150
NSBP 25	250	14185	2500	375	1818	3198	2418	400 O/D	1050	1150
NSBP 30	300	17000	3000	450	1818	3758	2418	500 O/D	1185	1285
NSBP 40	400	22650	4000	600	1818	4878	2418	500 O/D	1185	1285
NSBP 45	450	25325	4500	675	1818	5438	2418	500 O/D	1185	1285
NSBP 50	500	28330	5000	750	1818	5998	2418	500 O/D	1185	1285
NSBP 60	600	33996	6000	900	2622	4028	3172	600 I/D Twin wall	1350	1450
NSBP 65	650	36829	6500	975	2622	4303	3172	600 I/D Twin wall	1350	1450
NSBP 70	700	39620	7000	1050	2622	4578	3172	600 I/D Twin wall	1350	1450
NSBP 75	750	42495	7500	1125	2622	4908	3172	600 I/D Twin wall	1350	1450
NSBP 80	800	45330	8000	1200	2622	5415	3172	600 I/D Twin wall	1350	1450
NSBP 100	1000	56660	10000	1500	3128	4702	3678	750 I/D Twin wall	1525	1625
NSBP 125	1250	70820	12500	1875	3128	5741	3678	TBC*	TBC*	TBC*
NSBP 130	1300	73658	13000	1950	3128	6028	3678	TBC*	TBC*	TBC*
NSBP 150	1500	84990	15000	2255	3128	6780	3678	TBC*	TBC*	TBC*

Notes:

*Pipework and inverts sized on application

- > The dimensions given on this page are for guidance only
- > For precise tank sizes and configurations, please contact Marsh Civils
- > Number of access shafts will be built to suit site specifications and to maintain safe access for emptying
- > All dimensions in mm



Marsh:Hydroil™

Forecourt separators

For areas at 'significant risk' of oil contamination

Overview

Designed and tested to BS EN858 parts 1&2, Marsh Hydroil forecourt separators are manufactured from virgin unfilled resin offering exceptional durability, impact resistance and are guaranteed to be watertight and of uniform thickness. These combined properties ensure that the full range of separators stand up to the most rigorous conditions during their service life.

Internal working components, such as coalescing filters, weirs, oil skimmer plates, and their configurations offer the most modern and efficient oil/water separation capability available to the market today.

A wide choice of inlet and outlet positions are available on the units - detailed requirements should be provided at time of order (standard inlet and outlet positions will otherwise be fitted).

Operating principle

Marsh Hydroil forecourt separators are manufactured to a specific size in order to retain the potential spillage from a single compartment of a road tanker – currently up to 7,600 litres in the UK.

Key

- 1 Inlet
- 2 Oil level alarm (in 3" pipe)
- 3 Coalescer
- 4 Outlet
- 5 Access turrets

Flowpath

- Oil/water mixture
- Water

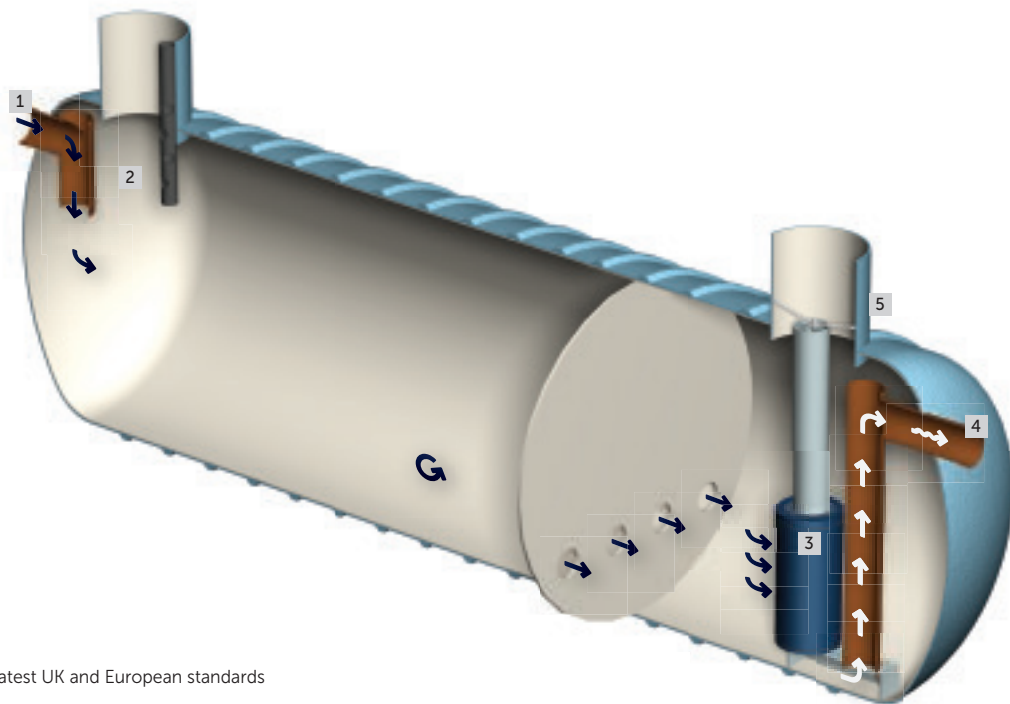

Benefits

- Designed and tested to meet latest UK and European standards
- Corrosion resistant
- Tank shells guaranteed for 25 years with a design life of 50 years
- Heavy duty shells enable installation in all ground conditions
- Easy access turrets for maintenance and servicing (Turret guards optional)
- Various alarm types available (Required by EN858-1)
- Variable invert depths and inlet/outlet configurations to suit individual site conditions
- Vented turrets dissipate excessive fumes and vapours

Typical applications

- Petrol stations
- Refuel facilities
- Fuel storage sites

Forecourt separator range

Model	Capacity litres	Width +/-50mm	Length +/-50mm	Height +/-50mm	Connection size	Inlet invert	Outlet invert
Class 1	10000	1800	4200	2200	160	700	800
Class 2	10000	1800	4200	2200	160	700	800

Notes:

- > The dimensions given on this page are for guidance only
- > For precise tank sizes and configurations, please contact Marsh Civils
- > Number of access shafts will be built to suit site specifications and to maintain safe access for emptying
- > All dimensions in mm

Illustrations shown for visual reference only



Wash-down separators and silt traps

Pollution prevention

Wash-down separators

Available in capacities from 2800-20,000 litres, Marsh wash-down separators safely remove silt and debris from vehicle wash-down facilities.

These units are primarily used on car wash bays, pressure wash facilities or other cleaning facilities where the effluent must be discharged to the foul water drainage system.

It is a legal requirement to install a silt trap or wash-down separator on commercial sites, such as vehicle wash bays, where there is an environmental risk of contamination from dirt, brake dust, traffic film residue, cleaning agents, oil, etc. In all cases, you should contact your local building control or environmental agency for specific site requirements.

Benefits

- Heavy duty shells enable installation in all ground conditions
- Tank shells guaranteed for 25 years with a design life of 50 years
- Variable invert depths and inlet/outlet configurations to suit individual site conditions
- Easy access turrets for maintenance and servicing (Turret guards optional)
- Optional Polylok filter can further reduce pollutants from entering the drainage system
- Various alarm types available (Required by EN858-1)
- Corrosion resistant

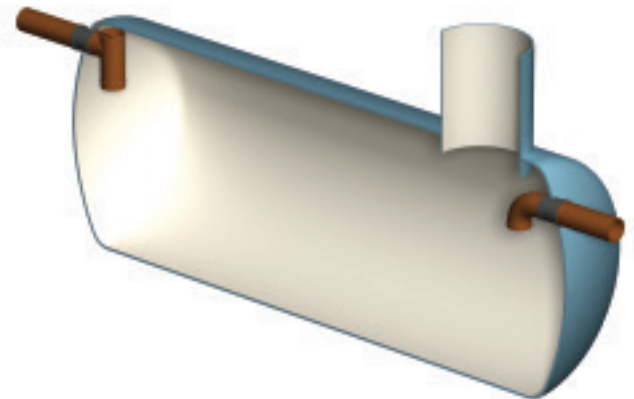

Wash-down separator range

Model	Capacity litres	Width +/-50mm	Length +/-50mm	Height +/-50mm	Connection size	Inlet invert	Outlet invert
WD2800	2800	1200	3000	1715	110	700	750
WD3800	3800	1200	4000	1715	110	700	750
WD4500	4500	1500	2650	2015	110	700	750
WD6000	6000	1800	2950	2300	110	700	750
WD8000	8000	1800	3600	2300	160	700	750
WD10000	10000	1800	4200	2300	160	700	750
WD12000	12000	1800	5200	2300	160	700	750
WD15000	15000	2500	3100	3000	160	700	750
WD18000	18000	2500	4100	3000	160	700	750
WD20000	20000	2500	4500	3000	160	700	750

Notes:

- > The dimensions given on this page are for guidance only
- > For precise tank sizes and configurations, please contact Marsh Civils
- > Number of access shafts will be built to suit site specifications and to maintain safe access for emptying
- > All dimensions in mm

Silt traps

With a capacity from 830-3400 litres, Marsh silt traps provide effective storage of silt and debris from vehicle wash-down facilities.

Positioned ahead of an oil separator, the silt trap gathers and stores silt and sediment, and prevents it from entering the oil separator system.

Benefits

- Heavy duty body enables installation in all ground conditions
- Hinged, galvanised steel grating provides structural integrity and easy emptying
- Tank body guaranteed for 25 years with a design life of 50 years

Silt trap

Model	Capacity litres	Length +/-50mm	Width +/-50mm	Height +/-50mm	Connection size	Outlet invert
CST1	830	1165	680	1060	110mm	240
CST2	1570	2180	680	1060	110mm	240
CST3	2300	3205	680	1060	110mm	240
CST4	3400	4230	680	1060	110mm	240

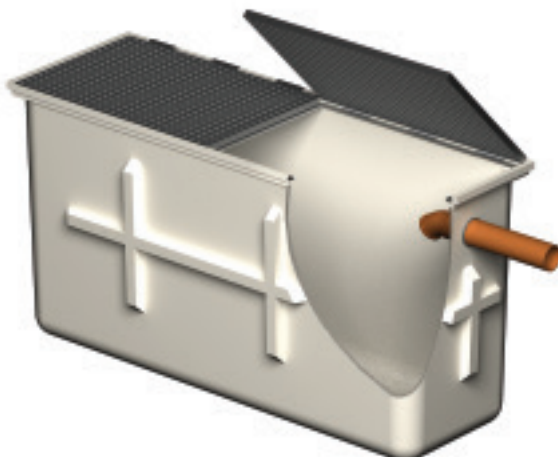

Marsh Industries

Providing world-class water and wastewater treatment solutions to the domestic, commercial and agricultural sectors from our UK manufacturing plants in Kettering, Raunds and Bridgwater.

Working smarter

Efficiently meeting the needs of our customers

We strive to be recognised as a collaborative and trusted partner for our customers, aligned to their business, and with a reputation for providing quality products that really do add value.

Innovative thinking

Enabling technologies that deliver tangible benefits

Working across many areas of the UK construction sectors our specialist innovation team combines 100+ years' experience of designing, manufacturing and testing wastewater treatment products that are proven to be economic, efficient and environmentally sensitive.

Compliant products

In line with building and environmental regulations

Our products are fully type-tested and certified to ensure compliance with relevant environmental permitting programmes and Building Regulations. Our extensive portfolio of product approvals and certification is available for viewing.

Delivering confidence

Extensive civils knowledge and experience

Customers specify Marsh products and services because they know we deliver from a solid foundation of knowledge, experience, product quality and proven performance.

Supporting your business

Specialist services to further enhance customer requirements

There are times when our customers need a little extra support. Whether this is on-site advice, backup support, specialist testing or bespoke project solutions, we offer a range of services when and where required.

Together we are a strategic partnership

Our core strength lies in the knowledge, experience and enthusiasm of our staff and our customers combined.



NBS Source
PARTNER



MARSH HQ AND FACTORIES
Units 2-20, Addington Business Park
Little Addington, Northamptonshire
NN14 4AS

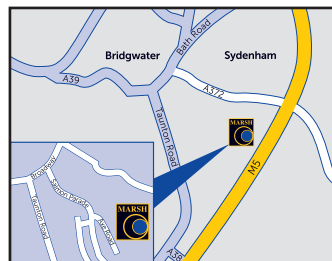

BRIDGWATER FACTORY
Axe Road, Colley Lane Industrial Est.
Bridgwater, Somerset TA6 5LN

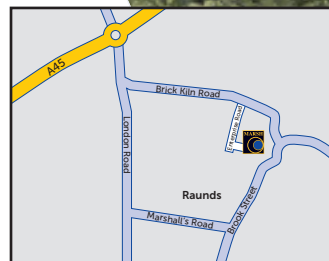

RAUNDS FACTORY
Enterprise Rd, Raunds,
Northamptonshire NN9 6JE

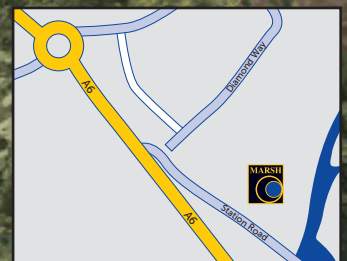

MARSH CIVILS OFFICE
Waterside House, Station Rd,
Irthlingborough,
Northamptonshire NN9 5QF

contracts@marshindustries.co.uk

+44 (0)1933 829470

www.marshcivils.co.uk

